



Jack Wechat



Jack Facebook



YouTube

JACK

China No.1

Shanghai stock
listed

2022.08

JACK TECHNOLOGY CO.,LTD

ADD:No.1008, Donghai Avenue East, Jiao jiang District, Taizhou City,
Zhejiang Province, China
TEL:0086-576-88177782

E-mail: sales@chinajack.com
www.chinajack.com

JACK

TOTAL SOLUTION PROVIDER

Intelligent Connection, Total Solution, Making Garment Intelligently Made Infinite Possibilities

- | Consulting Planning
- | Project Implementation
- | Management Coaching

- | Equipment Supply
- | Integrated Software
- | Professional Team

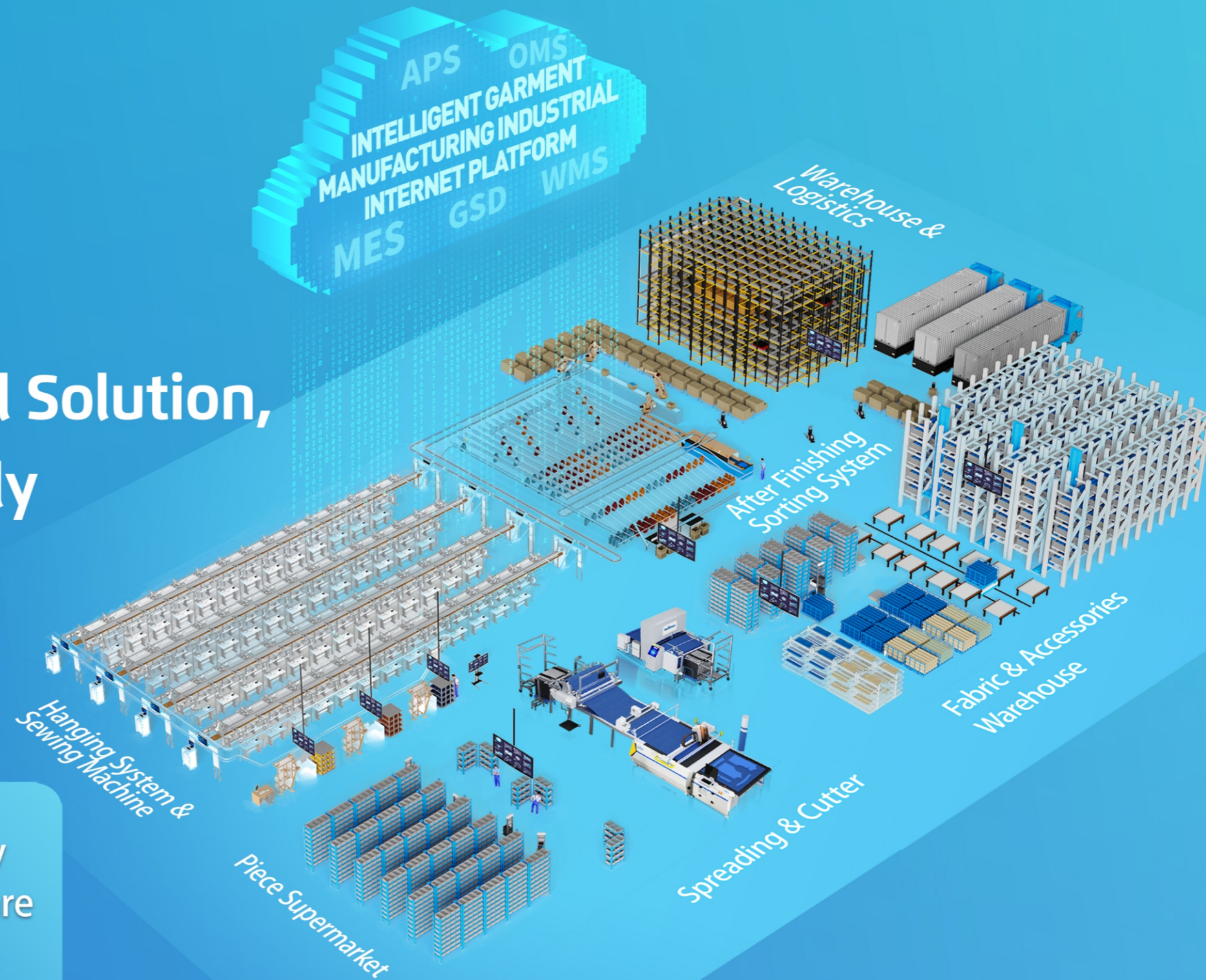

JACK STOCK

JACK bullmer MAICA VI.BE.MAC.

Everything Interconnected Intelligent-sewing Future

JACK+ Let us help you connect with
the intelligent-sewing future



Jack Wechat Jack Facebook YouTube

/// Intelligent Connection, Total Solution,
Making Garment Intelligently Made Infinite Possibilities

ABOUT JACK

Jack group (stock code: 603337) started in 1995, focusing and concentrating on the sewing equipment industry for 27 years. the world's largest R&D investment in the industry, fourteen major R&D centers, nearly 1000 people R&D team, 7 consecutive years ranking No. 1 in the world for industrial patents.

Jack is an international private high-tech enterprise specializing in the research, development, production and sales of industrial sewing machine. The A-share main board listed company, which has led the industry in sales for 12 consecutive years, and has achieved commercial success with more than 2 million garment factories in more than 150 countries around the world! Jack is the complete set of intelligent service providers, integrating clothing materials storage, intelligent cutting, hanging sewing, rear sorting, finished product storage, MES, WMS, APS and other software and hardware, helping global clothing enterprises to achieve intelligent manufacturing and digital management!

WONDERFUL JACK



I Strategic customer

休闲 牛仔类	Levi's	Lee	ck Calvin Klein	EVISU	GAP	DIESEL FOR SUCCESSFULL LIVING	AMERICAN EAGLE OUTFITTERS	PEACEBIRD 太平鸟	GIORDANO 纪得奴	QIHOZHIWANG 舒适之王 乔治王	Betty Barclay
运动 服类	adidas	NIKE	PUMA	PEAK	POLO RALPH LAUREN	LI-NING	Semir	YISHION 以纯	Walmart Save money. Live better.	DECATHLON 迪卡侬 运动专业超市 SPORTS MEGASTORE	ETERNA
西服 羽绒 棉服类	GXG	HLA 海澜之家	报喜鸟 SAINT ANGELO	JUDGER 庄吉	GUOREN 贵人	QINMAN 琴曼	AOBENNI	波司登 畅销全球72国	南极人 NANJIREN	HUBAO	EVER GLORY
快时尚 箱包类	H&M	ZARA COLLECTON 19	UNI QLO	KM	PRADA	GA	LV LOUIS VUITTON	BOSS HUGO BOSS	Yebaob 果豹集团	YEARCON 意尔康 匠心为你每一步	达芙妮 DAPHNE
童装 内衣 家纺 其他类	Balabala	AÍMER 爱慕	LUOLAI 罗莱家纺	罗兰家纺	浪莎 Langsha	晶苑集团 CRYSTAL GROUP	大商集团 MONARCH GROUP	天堂 Paradise	CBIQ 斯美泰包袋	宏达制衣	网易严选



Product list

Cutting Equipment Series

Jack Automatic Cutting Equipment	01
Jack Intelligent Hanging System	02
JK-PZ5 Super Accurate Knitted And Woven Dual Purpose Fabric Spreading Machine	03
JK-PS5 Super Accurate Knitted Fabric Spreading Machine	03
JK-PZ4 Super Speed Knitted And Woven Dual Purpose Fabric Spreading Machine	04
JK-T8 Automatic Cutting Machine	04

Lockstitch Machine Series

A7 Intelligent For Light And Heavy Duty Computerized Lockstitch Machine	05
A8 Intelligent Feeding Oil-free Lockstitch	07
A6F-E Computerized Needle Feed Lockstitch Machine	08
A5E Large Operation Space Computerized Lockstitch Machine	08
A4F Super Fast Computerized Lockstitch Machine	09
A4B Anti Thread-off Computerized Lockstitch Machine	09
A2B Auto Trimmer	10
F5 Power Saving Direct Drive Lockstitch Sewing Machine	11
JK-58450J Computerized Double Needle Lockstitch Machine	11
JK-5559F-W Computerized Edge Cutter Lockstitch Machine	12
JK-8558G Power Saving Chain Stitch Machine	12

Overlock Machine Series

C6 Intelligent Overlock Machine	13
C5S Short Thread Remaining Light And Heavy Quick Adjustable More Efficiency And Durable	15
C5T Variable Top Feed Computerized Overlock Machine	16
E3 High Speed Direct Drive Overlock Machine	16
E4S Light And Heavy Adjustable Power Saving Overlock Machine	17
JK-797TDI-4/KS/FR01 Small Cylinder-bed Variable Top Feed Super Fast Overlock Machine	18
Overlock Process Device	19

Interlock Machine Series

K6 Super Fast Intelligent Interlock Machine	21
K5E Large Operation Space Computerized Lockstitch Machine	23
JK-8770-01GX356/UT High Speed Computerized Small Cylinder-bed Interlock Machine	23

W4 High Speed Computerized Flat-bed Interlock Machine	24
JK-8670BDII/UT High Speed Computerized Small Cylinder-bed Interlock Machine	25
JK-8009VCDII/UTL High Speed Computerized Multi-needle Machine	26
JK-8740-460-02/D/AW/S 4 Needles 6 Thread Feed-off-arm Interlock Machine	27
JK-8787-01GX356/UT Super High Speed Computerized Cylinder-bed Interlock Machine	27
JK-1500-UT High Speed Feed-Up-The Arm, Cylinder Bed Interlock Machine	28
Interlock Device And Stitches Table	29

Special Machine Series

MX-100A Perfect Stitch Template Machine	31
MS-100A Large Size Template Machine	31
MG-60A Flexible Size Template Sewing Machine	32
MG-80A Intelligent Template Machine	32
JK-T5878-68B/78B Automatic Pocket Welting Machine	33
JK-T5878-58G Automatic Placket Setting Machine	33
JK-T9270D/9280D Direct Drive Feed-off-the Arm Machine	34
JK-T1790G Super Fast Computerized Button Hole Machine	35
JK-T781G New Integrated Electronic Lockstitch Buttonholing Machine	36
JK-T1900G Multi-Function Computerized Bartack Machine	37
JK-T1903GR Electronic Button Attaching Machine	39
JK-T1377E Integrated Computerized Button Attaching Machine	39
JK-T373G Integrated Computerized Button Attaching Machine	40

Heavy-duty Machine Series

JK-2002G Large Hook Computerized Heavy-duty Lockstitch Machine	41
JK-2060G Compound Feeding Computerized Lockstitch Machine For Heavy-duty	42
JK-2030G Top & Bottom Feeding Computerized Lockstitch Machine For Heavy-duty	42
H6 Top & Bottom feeding computerized lockstitch machine for heavy duty(Stepping type)	43
H5 Top & Bottom Feeding Computerized Lockstitch Machine For Heavy-duty	44
H5K Side Cutter Synchronous Computerized Heavy Duty Lockstitch Sewing Machine	45
H2 Top & Bottom Feeding Direct Drive Lockstitch Machine For Heavy Duty	45
S7 Intelligent-Control Computerized Post Bed Roller Feed Sewing Machine	46
S5 High Speed Computerized Post Bed Roller Feed Sewing Machine	47
JK-6591C/6592C Direct Drive Post Bed Sewing Machine	48
JK-6671C/6672C Intelligent-Control Computerized Post Bed Roller Feed Sewing Machine	48
JK-H1680 Automatic Three-stage Double-head intelligent Line Drawing Machine	49
Programmable Electronic Pattern Sewing Machine Series	50

JACK AUTOMATIC CUTTING EQUIPMENT

High Efficiency

Improve Quality

Increase Incomes



JK-PZ5



JK-T8

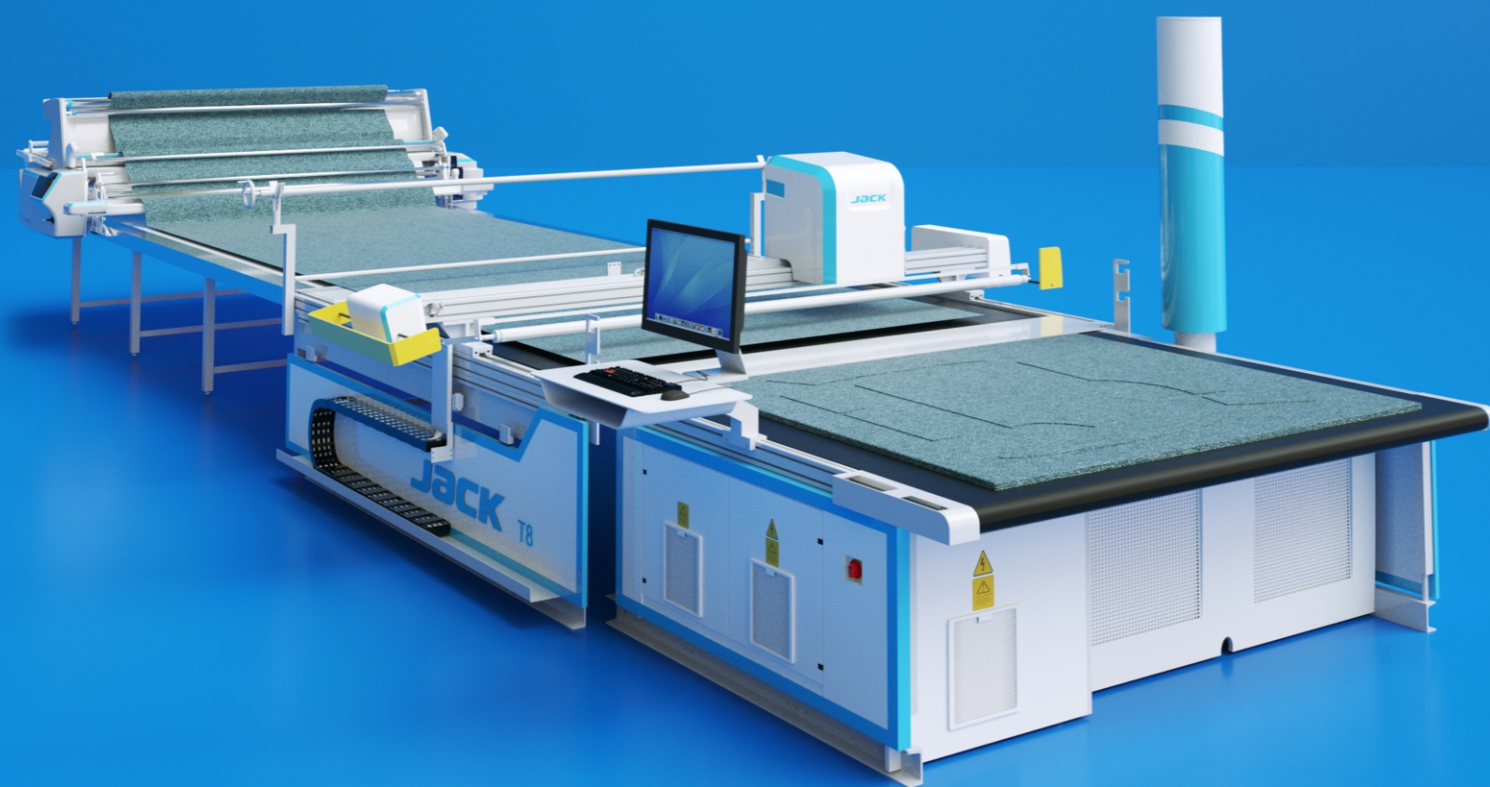

JACK INTELLIGENT HANGING SYSTEM

Reduce Manpower

Improve Efficiency

Optimize Management



JK-PZ5

Super Accurate Knitted And Woven Dual Purpose Fabric Spreading Machine

Spread accurated, no worry fabric tension, cutting fabric fast, stable, orderline



Servo control system



Automatic electric eye alignment



Automatic sharpening device



Flip device

Machine size LxWxH			2830x1970x1000mm			2930x1970x1000mm		
Maximum cloth width			N.W/G.W			Travel speed		
1900mm	2100mm	2200mm	585/875kg	652/985kg	645/1065kg	110m/min max		
Table width			Machine weight			Weight of cloth roll		
2130mm	2330mm	2430mm	355kg	375kg	395kg	60kg max		
Lay height (mm max)			Diameter of cloth roll			Power supply		
One-way:220		Zigzag: 150	450mm max			AC 220V±5%		

JK-PS5

Super Accurate Knitted Fabric Spreading Machine

Good choice for woven fabrics such as trousers, jackets, down, denim, etc.



Servo control system



Automatic sharpening device

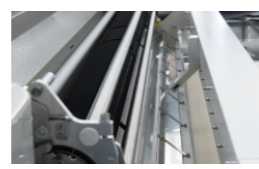

Automatic tension control



Flip device

Machine size LxWxH			2600x1650x800mm			Travel speed		
2300x1650x800mm			N.W/G.W			110m/min max		
Maximum cloth width			Machine weight			Weight of cloth roll		
1600mm	1900mm		475/705kg	525/785kg		200kg max		
Table width			Diameter of cloth roll			Power supply		
1830mm	2130mm		450mm max			AC 220V±5%		
Lay height (mm max)								
One-way:220		Zigzag: 150						

JK-PZ4

Super Speed Knitted And Woven Dual Purpose Fabric Spreading Machine

Compared with manual spreading, save 4-6 workers, the cost will be recovered in half a year



Servo control system



Cable start and stop function

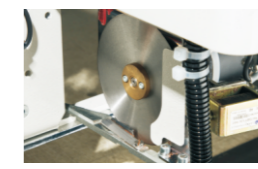

Automatic sharpening device



Parameter memory function

Machine size LxWxH			2830x1970x1000mm			2930x1970x1000mm		
2630x1970x1000mm			N.W/G.W			Travel speed		
Maximum cloth width			Machine weight			110m/min max		
1900mm	2100mm	2200mm	585/875kg	652/985kg	645/1065kg	Weight of cloth roll		
Table width			Diameter of cloth roll			60kg max		
2130mm	2330mm	2430mm	450mm max			Power supply		
Lay height (mm max)			AC 220V±5%					
One-way:220		Zigzag: 150						

JK-T8

Automatic Cutting Machine

High cost performance, high productivity, stable and durable

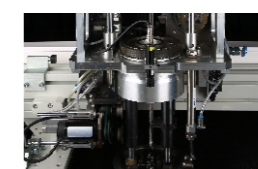

High quality cutting head structure



Aluminium cutter base advantages

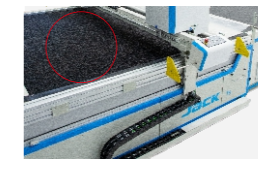

High quality bristles

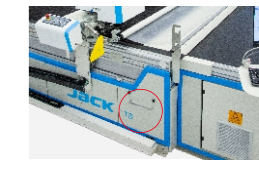

Built-in automatic filter systems

Cutting Length		Power Supply		Max. Speed		Rated knife frequency	
1800mm	2500mm	AC400V±5%		60m/min		5000r/min	
Cutting Width		Total power		Position Accuracy		Vacuum Negative Pressure	
1800mm	2000mm 2200mm	22kw		< 0.1mm		≥ -0.20bar	
Max. Cutting Height		Air Supply		Max. Acceleration		Noise	
80mm after vacuum compressed		0.6Mpa		0.8g		≤75db	
System Communication							
EtherCat							

Digital setting, one-key presents the best sewing stitch for all kinds of fabric

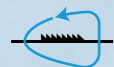
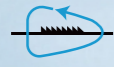
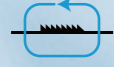
Locus type	Main features	Suitable range
Locus 1 Conventional fabric	 Suitable for more than 80% of conventional fabrics	Work uniforms, woolen coats, windbreakers, casual pants, etc.
Locus 2 Slippery fabric	 Without layers wrinkles	Women's clothing, pajamas, sun protection clothing, and jackets
Locus 3 Soft and thick fabric	 Without skipping stitches and wrinkles	Sportswear, underwear, light down jacket, dresses, etc.
Locus 4 Thick fabric	 Smooth for cross stitch sewing, precisely needle distance, no needle break	coats, jackets, sweaters, denim, etc.

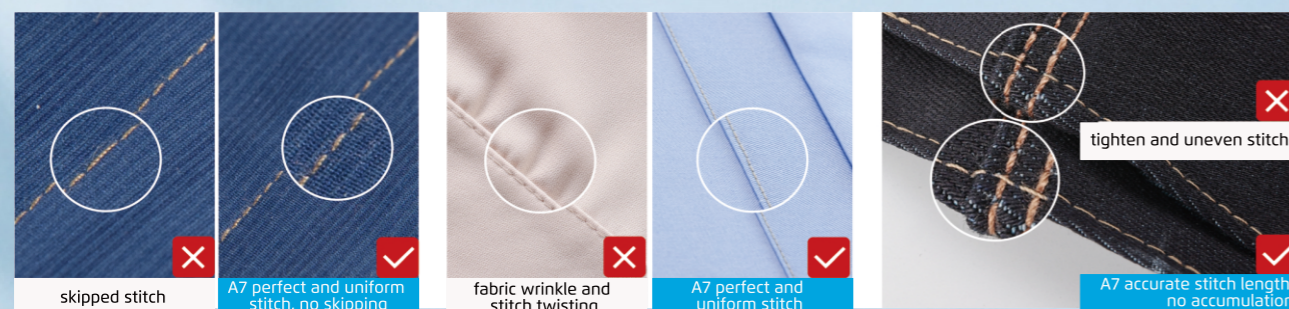

A7⁺ | Intelligent For Light And Heavy Duty Computerized Lockstitch Machine

Digital Setting, One-key Presents The Best Sewing Stitch For All Kinds Of Fabric



Suitable for clothing items such as

shirts, suits, pants, down jackets, etc.

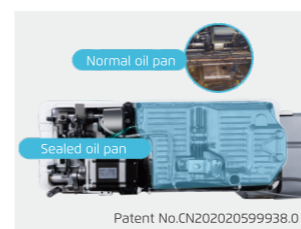

Sealed oil pan, avoid fabric pollution, oil free.



Stitch cross fabric smoothly, no breaking.



Accurate stitch length, easy to lock.

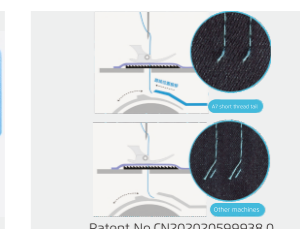

Control the thread tail within 3.5mm after trimming.

Model	Needle	Stitch Length (mm)	Presser Foot Lifting Height (mm)	Max. Speed (s.p.m)	A	M	H	Volume (mm)	Net weight/ Gross weight (kg)	Applicable fabric
A7 ⁺ -D	DBx1 11-18#	5	5-13	5000	✓	✓	/	690x295x550	40/46	5mm stitch length, applicable light and medium woven and knitted fabric
A7 ⁺ -D-7	DBx1 11-18#	7	5-13	5000	✓	✓	/	690x295x550	40/46	7mm stitch length, applicable and medium fabric and heavy duty material, like home textiles, curtain, non-woven fabric
A7 ⁺ -DH	DPx5 18-21#	5	5-13	4000	/	/	✓	690x295x550	40/46	5mm stitch length, applicable heavy duty, like denim fabric



A8^{TD} | Intelligent Feeding Oil-free Lockstitch

Intelligent IoT, Oil-free Sewing



Suitable for clothing items such as

shirts, suits, pants, down jackets, etc.



Sewing bone smoothly, no needle broken.



Double-knife, optional less bird's nest, no need trim again.

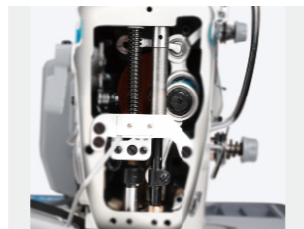

Semi-dry head, oil free.



305mm Large sewing space.

Model	Needle	Stitch Length (mm)	Presser Foot Lifting Height (mm)	Max. Speed (s.p.m)	A	M	H	Volume (mm)	Weight (kg)	Applicable fabric
A8	DBx1 11-18#	5	5-13	5000	✓	✓	/	695x315x670	42/49	5mm stitch length, applicable light and medium woven and knitted fabric
A8 ^{TD}	DBx1 11-18#	5	5-13	5000	✓	✓	/	695x315x670	42/49	5mm stitch length, applicable light and medium woven and knitted fabric
A8 ^N	DBx1 11-18#	5	5-13	5000	✓	✓	/	695x315x670	42/49	5mm The bird's nest with less needle pitch issuitable for nailing trademarks

A6F-E | Computerized Needle Feed Lockstitch Machine

Needle Feeding, No Thread Tail, Large Space



Suitable for clothing items such as

shirts, suits, pants, down jackets, etc.

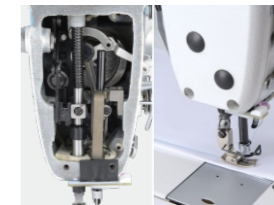

Feed smoothly; Avoid of layers offset.

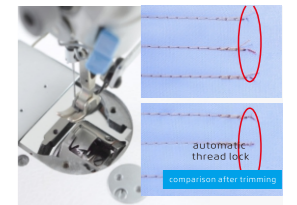

Beautiful stitches without short thread tail.



Large space.



Sealed oil pan, no oil, no trouble.

Model	Needle	Thread No.	Stitch Length (mm)	Presser Foot Lifting Height (mm)	Max. Speed (s.p.m)	A/M	H	Volume (mm)	Weight (kg)
A6F-E	Dbx1 11-18#	2	4.5	5-13	4000	✓		710x355x580	44/51
A6F-EH	DPx5 18-21#	2	4.5	5-13	3000		✓	710x355x580	44/51
A6F-E-PK	DBx1 11-18#	2	4.5	5-13	4000	✓		710x355x580	46.5/53.5
A6F-EH-PK	DPx5 18-21#	2	4.5	5-13	3000		✓	710x355x580	46.5/53.5

Note: PK is integrated rear puller, factory standard.

A5E | Large Operation Space Computerized Lockstitch Machine

Large Space, High Precision Stitch, Short Thread Remaining

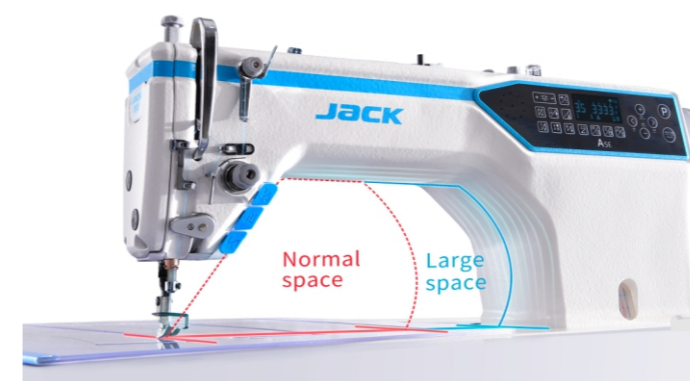

Suitable for clothing items such as

shirts, suits, pants, down jackets, etc.

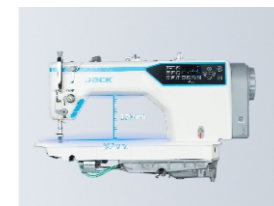

The Largest Operation Space 305mmx130mm, Give Sewing More Imagination



High Precision Stitch

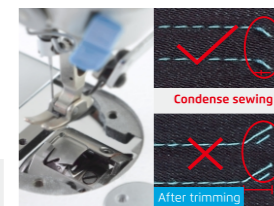

Beautiful Stitches, Short Thread Remaining

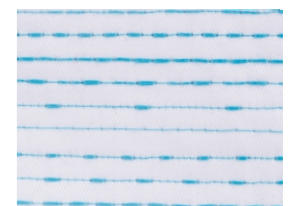

Variable Stitches, Fashionable And Beautiful

Model	Needle	Thread No.	Stitch Length (mm)	Presser Foot Lifting Height (mm)	Max. Speed (s.p.m)	Light/Medium Heavy Duty	Heavy Duty	Volume (mm)	Weight (kg)
A5E	DBx1 11-18#	2	5	5-13	5000	✓		690x295x550	42.5/48.5
A5E-H-M	DBx1 11-18#	2	5	5-13	5000	✓		690x295x550	42.5/48.5
A5E-H	DPx5 18-21#	2	5	5-13	3500		✓	690x295x550	42.5/48.5
A5E-7	DBx1 11-18#	2	7	5-13	3500	✓		690x295x550	42.5/48.5

Note: Japanese hook, auto trimming, auto reverse sewing, auto presser foot lifter, electronical thread nipper, 5mm stitch length, 7mm stitch length is optional(-7).

A4F | Super Fast Computerized Lockstitch Machine

Easy Operation, Light Sound, More Durable



Suitable for clothing items such as shirts, suits, pants, down jackets, etc.

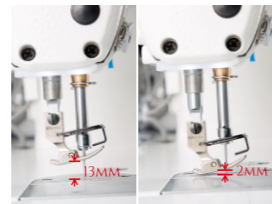

Germany design, unique image, precise details.



Stepping motor control, accurate stitch length.



Stepping motor control, more quiet.

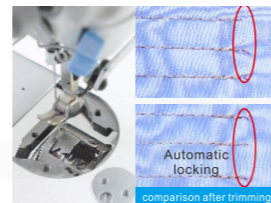

Short thread remaining, no need to trim again.

Model	Needle	Thread No.	Stitch Length (mm)	Presser Foot Lifting Height (mm)	Max. Speed (s.p.m)	A/M	H	Volume (mm)	Weight (kg)
A4F-D	Dbx1 11-18#	2	5	5-13	5000	✓		690×295×550	38.6/44.6
A4F-DH-M	Dbx1 11-18#	2	5	5-13	5000	✓		690×295×550	38.6/44.6
A4F-DH	DPx5 18-21#	2	5	5-13	3500		✓	690×295×550	38.6/44.6

A4B | Anti Thread-off Computerized Lockstitch Machine



Suitable for clothing items such as shirts, suits, pants, down jackets, etc.

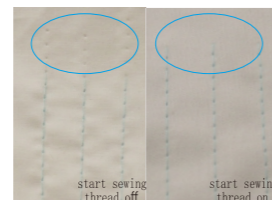

Bottom thread clamping to anti thread-off while starting sewing.

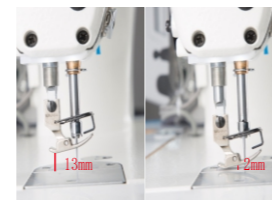

Stepping motor control, presser foot height adjustable.



High precision stitch.



Variable stitches, fashionable and beautiful.

Model	Needle	Thread No.	Stitch Length (mm)	Presser Foot Lifting Height (mm)	Max. Speed (s.p.m)	A/M	H	Volume (mm)	Weight (kg)
A4B-C-22	Dbx1 11-18#	2	5	5-13	5000	✓	/	690×295×550	40/46
A4B-CH-M-22	Dbx1 11-18#	2	5	5-13	5000	✓	/	690×295×550	40/46
A4B-CH-22	Dp×5 18-21#	2	5	5-13	3500	/	✓	690×295×550	40/46
A4B-C-7-22	Dbx1 11-18#	2	7	5-13	3500	✓		690×295×550	40/46
A4B-CHL-7-22	Dp×5 18-21#	2	7	5-13	3500		✓	690×295×550	40/46

A2B | Auto Trimmer



Suitable for clothing items such as shirts, suits, pants, down jackets, etc.

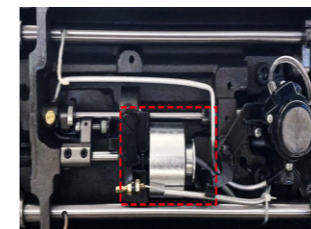

Automatic thread trimmer, achieve high efficiency.

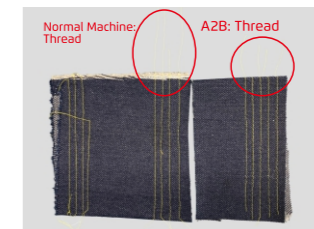

Thread tail more than 7cm, design with large air flow. A2B just 4cm approximately, Save thread.

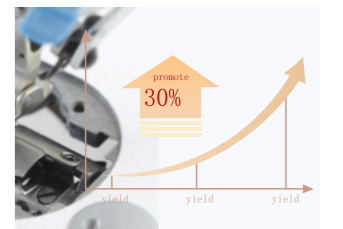

30% efficiency improve.

Model	Needle	Thread No.	Stitch Length (mm)	Presser Foot Lifting Height (mm)	Max. Speed (s.p.m)	A	M	H	Volume (mm)	Weight (kg)
A2B-C	Dbx1 11-18#	2	5	5-13	5000	✓	✓		645×248×550	30/36.5
A2B-CH	DPx5 18-21#	2	5	5-13	3500			✓	645×248×550	30/36.5
A2B-CH-7	DPx5 18-21#	2	7	5-13	3500		✓		645×248×550	30/36.5
A2B-CH-7	DBx1 11-18#	2	5	5-13	3500	✓	✓		645×248×550	30/36.5

F5 | Power Saving Direct Drive Lockstitch Sewing Machine



Suitable for clothing items such as

shirts, suits, pants, down jackets, etc.



High-voltage Low-voltage
Power saving and high efficiency.



Easy and smart panel.



Safety switch



High voltage protection

Direct drive integration, Intelligence.

Model	Needle	Thread No.	Stitch Length (mm)	Presser Foot Lifting Height (mm)	Max. Speed (s.p.m)	A/M	H	Volume (mm)	Weight (kg)
F5	Dbx1 11-18#	2	5	5-13	5000	√		635×248×550	31.5/38.2
F5-H	DPx5 18-21#	2	5	5-13	3500		√	635×248×550	31.5/38.2
F5-HL-7	DBx1 11-18#	2	7	5-13	3500		√	635×248×550	31.5/38.2
F5-7	DPx5 18-21#	2	7	5-13	3500	√		635×248×550	31.5/38.2
F5-H-7	DPx5 18-21#	2	7	5-13	3000		√	635×248×550	31.5/38.2

JK-58450J | Computerized Double Needle Lockstitch Machine

Auto Cornering; Large Space



Suitable for clothing items such as

Umbrella, denim, T-shirt, etc. with chain stitching



Auto corner sewing.

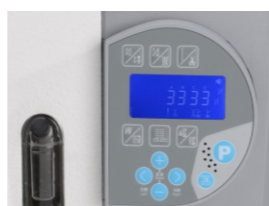

Voice guide, one key to reset.

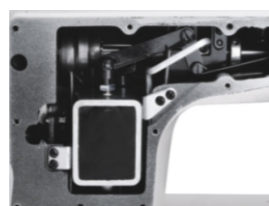

Built-in presser foot lifter.

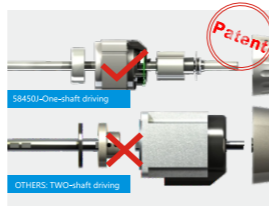

One main shaft, stable and fast.

Model	Needle	Stitch Length (mm)	Needle Gauge (mm)	Presser Foot Lifting Height (mm)	Max. Speed (s.p.m)	Application	Function	Auto Corner Sewing	Large Hook	Volume (mm)	Weight (kg)
JK-58420B-003/JK-58420B-005	DP x 5 11-16#/14-22#	4/5	6.4	7-13	3000	A/H	Straight Stitch			725 × 320 × 675	47.5/58
JK-58450B-003/JK-58450B-005	DP x 5 11-16#/14-22#	5	6.4	7-13	3000	A/H	Corner Stitch			725 × 320 × 675	47.5/58
JK-58720B-003/JK-58720B-005	DP x 5 11-16#/14-22#	7	6.4	7-13	3000	A/H	Straight Stitch		√	725 × 320 × 675	47.5/58
JK-58750B-003/JK-58750B-005	DP x 5 11-16#/14-22#	7	6.4	7-13	3000	A/H	Corner Stitch		√	725 × 320 × 675	47.5/58
JK-58420J-403E/JK-58420J-405E	DP x 5 11-16#/14-22#	4/5	6.4	7-13	3000	A/H	Straight Stitch			725 × 320 × 675	53/63
JK-58450J-403E/JK-58450J-405E	DP x 5 11-16#/14-22#	5	6.4	7-13	3000	A/H	Corner Stitch			725 × 320 × 675	53/63
JK-58450J-413E/JK-58450J-415E	DP x 5 11-16#/14-22#	5	6.4	7-13	3000	A/H	Corner Stitch	√		725 × 320 × 675	53/63
JK-58720J-403E/JK-58720J-405E	DP x 5 11-16#/14-22#	7	6.4	7-13	3000	A/H	Straight Stitch		√	725 × 320 × 675	53/63
JK-58750J-403E/JK-58750J-405E	DP x 5 11-16#/14-22#	7	6.4	7-13	3000	A/H	Corner Stitch		√	725 × 320 × 675	53/63
JK-58750J-413E/JK-58750J-415E	DP x 5 11-16#/14-22#	7	6.4	7-13	3000	A/H	Corner Stitch	√		725 × 320 × 675	53/63

Note: 1. B is direct drive, Chinese hook is standard; the imported hook can be optional.
2. J is computerized, auto trimmer, auto reverse, auto presser foot lifter, auto wiper are as standard; the electronic thread tension is optional; the suffix is 103E/105E;
3. Optional needle positions for computerized (distance between needles mm): 1/8 (3.2) / 3/16 (4.8) / 1/4 (6.4) / 5/16 (7.9) / 3/8 (9.5) / 1/2 (12.7) / 5/8 (15.9) / 3/4 (19) / 7/8 (22.2) / 1 (25.4) / 1 1/8 (32) / 5/32 (4) / 3/16 (4.8) / 1/4 (6.4) / 5/16 (7.9) / 3/8 (9.5) / 7/16 (11.1) / 1/2 (12.7) / 5/8 (15.9) / 3/4 (19) / 7/8 (22.2) / 1 (25.4) / 1-1/4 (31.8) / 1-1/2 (38.1) / 1-5/8 (41.3) / 1-13/16 (46) .

JK-5559F-W | Computerized Edge Cutter Lockstitch Machine

Semi-dry, Stable Edge Cutter



Suitable for clothing items such as

shirts, suits, pants, down jackets, etc.



Stepping motor control, accurate stitch length

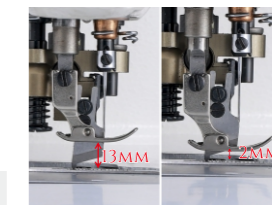

Stepping motor control presser foot lifter, less effort and more convenience



Noiseless reverse sewing, quiet and comfortable.

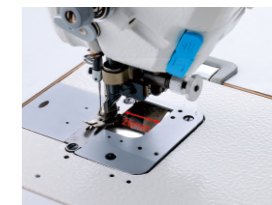

26mm Blanking space

Model	Needle	Thread No.	Stitch Length (mm)	Presser Foot Lifting Height (mm)	Max. Speed (s.p.m)	Cutter needle position group	Volume (mm)	Weight (kg)
JK-5559F-W	Db□1 11-18#	2	5	5-13	4000	1/8	605□205□550	40/46
JK-5559F-W (1/4)	Db□1 11-18#	2	5	5-13	4000	1/4	605□205□550	40/46
JK-5558G-W	Db□1 11-18#	2	5	5-13	4000	1/8	645□248□550	32/38.7
JK-5558G	Db□1 11-18#	2	5	5-13	4000	1/8	645□248□550	32/38.7
JK-5558G-W (1/4)	Db□1 11-18#	2	5	5-13	4000	1/4	645□248□550	32/38.7
JK-5558G (1/4)	Db□1 11-18#	2	5	5-13	4000	1/4	645□248□550	32/38.7
JK-5558G-WT	Db□1 11-18#	2	5	5-13	4000	3/16	645□248□550	32/38.7
JK-5558G-T	Db□1 11-18#	2	5	5-13	4000	3/16	645□248□550	32/38.7

JK-8558G | Power Saving Chain Stitch Machine

Semi-dry, Chainstitch trace



Suitable for clothing items such as

Umbrella, denim, T-shirt, etc. with chain stitching

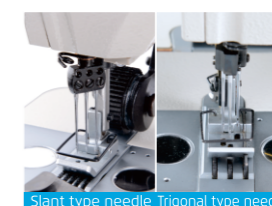

Slant type needle Trigonal type needle
Two needle gauges (JK-8560G)

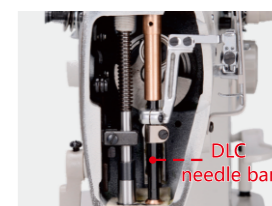

Semi-dry



Rear puller

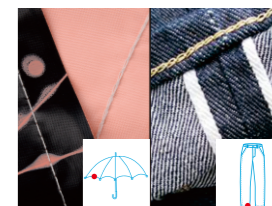

链式线迹

Model	Needle Array	Needle Gauge	Needle	Needle No.	Thread No.	Needle Distance (mm)	Presser Foot Lifting Height (mm)	A	M	H	Max. Speed (s.p.m)	Volume (mm)	Weight (kg)
JK-8558G-WZ	Parallel Double Needle	1/4, 3/16	TV□7 14#	2	4	1.4-4	5.5 (knee Control 10-12)	√	√		4000	670□275□595	38/46
JK-8558G-1WZ	Single Needle	1/8, 3/8	TV□7 14#	1	2	1.4-4	5.5 (knee Control 10-12)	√	√		4000	670□275□595	38/46
JK-8558G-2WZ	Vertical Double Needle	3/16	TV×7 14#	2	4	1.4-4	5.5 (knee Control 10-12)	√	√		4000	670×275×595	38/46
JK-8560G-WZ	Slant Three Needle	1/8	TV×7 14#	3	6	1.4-4	5.5 (knee Control 10-12)	√	√		4000	670×275×595	38/46
JK-8560G-WZ-PL	Slant Three Needle	1/8	TV×7 18#	3	6	1.4-4	5.5 (knee Control 10-12)		√		4000	670×275×595	38/46
JK-8560G-PHWZ	Trigonal Three Needle	1/8	TV×7 18#	3	6	1.4-4	5.5 (knee Control 10-12)	√	√		4000	670×275×595	38/46

Note: PL: rear puller; W: dry head; Z: Zhong Bang control box; P: Trigonal Three Needle; H: Heavy material

C6 | Intelligent Overlock Machine

Sewing Mode	Suitable sewing range	Advantage
Auto	Automatically adapt to match the thickness of the fabric and switch to the corresponding mode	Solve the quick return of small order, and issue of frequent switching between thickness and thinness. Worry-free switching between thickness
A (light)	Suitable for sewing thin fabrics, Mesh materials, such as single-layer knitting, Mesh, etc.	The stitches are smooth without wrinkles
M (medium)	Suitable for sewing conventional medium and heavy materials, such as T-shirts, woven materials, etc.	Wide sewing range
H (Heavy duty)	Suitable for sewing heavy duty materials, such as jeans, thick sweaters, etc.	Strong power and high efficiency

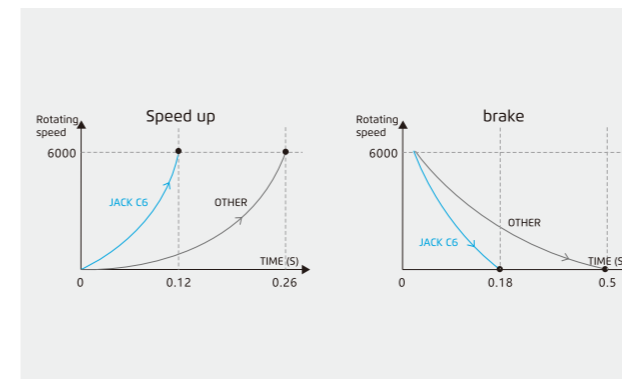

Operating more briskly, light voice, comfortable and more efficient.

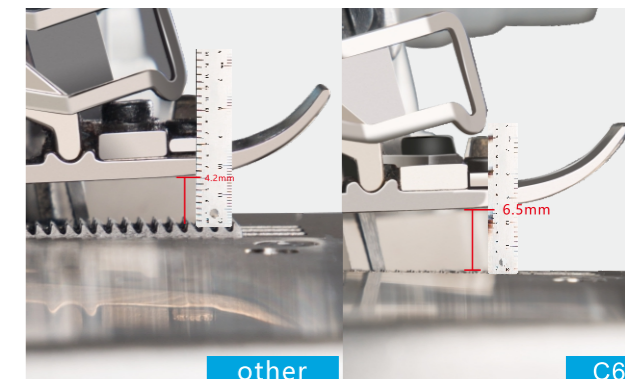

Feeding space is large, easy sewing and not scraping material.

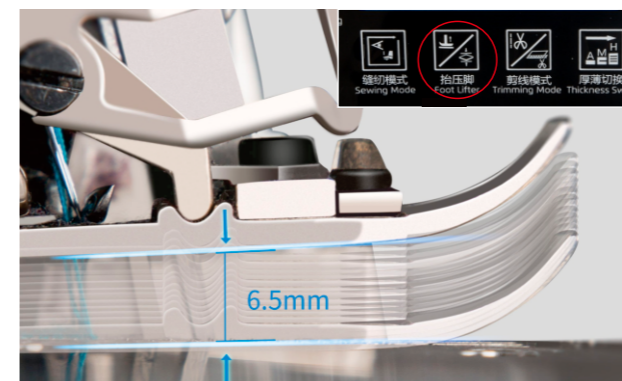

Electronic digital control, precise and convenient.

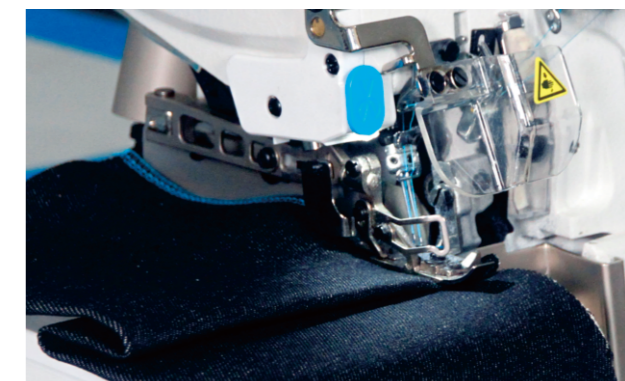

Intelligent recognition of thick materials when sewing makes sewing smoother.

Suitable for clothing items such as

T-shirts, underwears, casual jeans and other middle and high-level clothes

Model	Functions	Needle	Needle NO.	Thread NO.	Needle Distance (mm)	Stitch Width (mm)	Stitch Length (mm)	Differential Ratio	Presser Foot Lifting Height (mm)	Max. speed (S.p.m)	Volume (mm)	Weight (kg)
C6-02x250	Pocket binding seam	DCx27 14#	2	4	5	5	0.8-4.2	0.7-2	3.5	7000	525x360x510	33/41
C6-3-02/233	Plain seam	DCx27 11#	1	3	/	4	0.8-4.2	0.7-2	5	7000	525x360x510	33/41
C6-3-32R2/223	Narrow stitch seam	DCx27 9#	1	3	/	1.5	0.8-4.2	0.7-2	5	7000	525x360x510	33/41
C6WF-3-02/213	No-woven	DCx27 14#	1	3	/	4	0.8-8.5	0.7-2	5	7000	525x360x510	33/41
C6-4-M03/333	Plain seam	DCx27 11#	2	4	2	2x4	0.8-4.6	0.7-2	6	7000	525x360x510	33/41
C6-4-M03/333/H/M	Heavy duty	DCx27 11#	2	4	2	2x4	0.8-4.6	0.7-2	6	7000	525x360x510	33/41
C6-4-M03/333/K	knitting fabric	DCx27 11#	2	4	2	2x4	0.8-3.8	0.7-2	6	6500	525x360x510	33/41
C6MJ-4-53/233	Tower ending	DCx27 11#	2	4	2	2x4	0.8-4.2	0.7-2	5	7000	525x360x510	33/41
C6-5-53/233	Strip attach seam	DCx27 14#	2	5	3	3x5	0.8-4.2	0.7-2	5	7000	525x360x510	33/41
C6-5-03/233	5x5	DCx27 14#	2	5	5	5x5	0.8-4.2	0.7-2	5	7000	525x360x510	33/41
C6-5-03/333	3x4	DCx27 14#	2	5	3	3x4	0.8-4.2	0.7-2	5	7000	525x360x510	33/41
C6-5-A04/435	Extreme heavy	DCx27 19#	2	5	5	5x6	0.8-5	0.7-2	7	7000	525x360x510	33/41
C6-5-M04/435	Denim fabric	DCx27 19#	2	5	5	5x6	0.8-5	0.7-2	7	7000	525x360x510	33/41
C6-6-03/333	Plain seam	DCx27 11#	3	6	3x2	3x2x4	0.8-4.2	0.7-2	5	7000	525x360x510	33/41
C6-6-M04/435	Denim fabric	DCx27 19#	3	6	5x2.5	5x2.5x3.5	0.8-5	0.7-2	7	7000	525x360x510	33/41

Note: H/M: Widely thickness adaptability, Optional X(Suction pipe cutter). Optional SD(Front and rear air suction device), Machine volume: 525x360x510(mm), Total Weight33/41(kg).

C5S Short Thread Remaining Light And Heavy Quick Adjustable More Efficiency And Durable

Short Thread Remaining, Light And Heavy Quick Adjustable, More Efficiency And Durable



Suitable for clothing items such as

T-shirts, underwears, casual jeans and other middle and high-level clothes



Front and back suction, clean sewing.

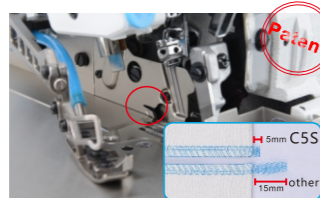

Short thread remaining, no need extra trimming.



More efficiency durable and stable.

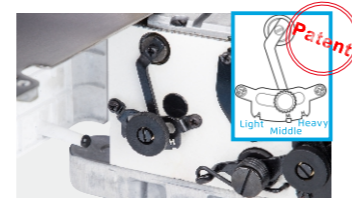

Light to medium to heavy adjustable, Widely range.

Model	Functions	Needle	Needle No.	Thread No.	Needle Distance (mm)	Stitch Width (mm)	Stitch Length (mm)	Differential Ratio	Presser Foot Lifting Height (mm)	Max. Speed (s.p.m)	Volume (mm)	Weight (kg)
C5S-02×250/AT	Pocket Binding	DC×27 14#	2	4	5	-	4	0.7-2	3.5	7000	525×360×630	33/44
C5S-3-02/233/KS	Plain Seaming	DC×27 11#	1	3	-	4	4	0.7-2	5	7000	525×360×630	33/44
C5S-3-32R2/223/KS	Condense seaming	DC×27 9#	1	3	-	1.5	4	0.7-2	5	7000	525×360×630	33/44
C5SWF-3-02/213/AT	Non-Woven	DC×27 14#	1	3	-	4	8.5	-	5.5	7000	525×360×630	33/44
C5S-4-M03/333/KS	Plain Seaming	DC×27 11#	2	4	2	4	4.6	0.7-2	5.5	7000	525×360×630	33/44
C5S-4-M03/333/H/M/KS	Heavy Duty	DC×27 11#	2	4	2	4	4.6	0.7-2	6	7000	525×360×630	33/44
C5S-4-83/323/BK	Pneumatic Back Latching	DC×27 11#	2	4	2	4	4.6	0.7-2	3.5	7000	525×360×630	33/44
C5SMJ-4-53/233/AT	Towel Ending	DC×27 11#	2	4	2	4	4	0.7-2	5	7000	525×360×630	33/44
C5S-5-53/233/AT	Strip Attaching	DC×27 14#	2	5	3	4	4	0.7-2	5	7000	525×360×630	33/44
C5S-5-03/233/KH	5×5 Stitch	DC×27 14#	2	5	5	5	4	0.7-2	5	7000	525×360×630	33/44
C5S-5-03/333/KH	3×4 Stitch	DC×27 14#	2	5	3	4	4	0.7-2	5	7000	525×360×630	33/44
C5S-5-A04/435/AT	Extra Heavy Duty	DC×27 19#	2	5	5	6	5	0.8-1.5	7	7000	525×360×630	33/44
C5S-5-M04/435/AT	Especially for Denim	DC×27 19#	2	5	5	6	5	0.8-1.5	7	7000	525×360×630	33/44
C5S-6-03/333/AT	Plain Seaming	DC×27 11#	3	6	3x2	4	4	0.7-2	5	7000	525×360×630	33/44
C5S-6-M04/435/AT	Especially for Denim	DC×27 19#	3	6	5x2.5	3.5	5	0.8-1.5	7	7000	525×360×630	33/44

Note:KS:Vertical suction device; KH:Horizontal suction device; AT:Pneumatic cutter trimming; H/M: Wide range for heavy duty; Optional CSSW (Semi-dry)

C5T Variable Top Feed Computerized Overlock Machine

Good For Heavy Materials Sewing, Quick Response, No Dislocation



Suitable for clothing items such as

shirts, suits, pants, down jackets, etc.



fabric feeding smoothly, adapt widely

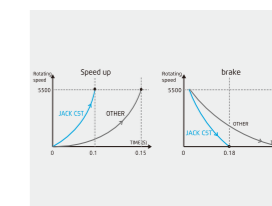

super fast start and stop, response fastly



top and bottom variable feeding, strong in feeding fabric

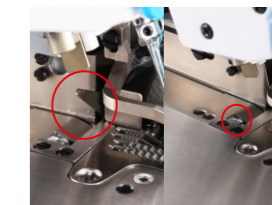

precise trimming, avoid of fabric trimming

Model	Functions	Needle	Needle No.	Thread No.	Needle Distance (mm)	Stitch Width (mm)	Stitch Length (mm)	Differential Ratio	Presser Foot Lifting Height (mm)	Max. Speed (s.p.m)	Volume (mm)	Weight (kg)
C5T-4-M03/333	Plain Seaming	DC×27 11#	2	4	2	4	4.6	0.7-2	5.5	6000	505×360×565	29.2/39.8
C5T-4-M04/435	Extra Heavy Duty	DC×27 14#	2	4	2	4	7	0.8-1.5	6	6000	505×360×565	29.2/39.8
C5T-4-A04/435	Especially For Denim	DC×27 14#	2	4	2	4	7	0.8-1.5	6	6000	505×360×565	29.2/39.8
C5T-5-03/233	5x5 Stitch	DC×27 14#	2	5	5	5	3.8	0.7-2	5	6000	505×360×565	29.2/39.8
C5T-5-03/333	3x4 Stitch	DC×27 14#	2	5	3	4	3.8	0.7-2	5	6000	505×360×565	29.2/39.8
C5T-5-03/333/H	3x4 Stitch	DC×27 14#	2	5	3	4	3.8	0.7-2	5	6000	505×360×565	29.2/39.8
C5T-5-A04/435	Especially For Denim	DC×27 19#	2	5	5	6	5	0.8-1.5	7	6000	505×360×565	29.2/39.8

E3 High Speed Direct Drive Overlock Machine

Power Saving, Easy Operation



Suitable for clothing items such as

shirts, suits, pants, down jackets, etc.

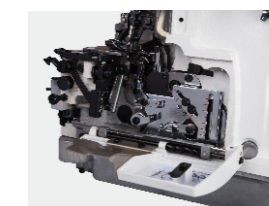

Optimized thread take-up mechanisms, beautiful sewing stitch.

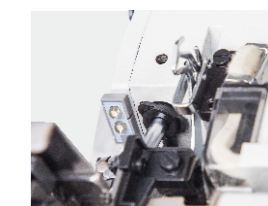

Fully enclosed needle bar oil return device, clean sewing.



Integrated handwheel design.



Easy operation, quick response.

Model	Functions	Needle	Needle No.	Thread No.	Needle Distance (mm)	Stitch Width (mm)	Stitch Length (mm)	Differential Ratio	Presser Foot Lifting Height (mm)	Max. Speed (s.p.m)	Volume (mm)	Weight (kg)
E3-3-M1-15	Light material	9#	1	3	/	1.5	4.6	0.7-2	5.5	5500	495x355x545	27.6/36.7
E3-3-M2-04	Plain seaming	11#	1	3	/	4	4.6	0.7-2	5.5	5500	495x355x545	27.6/36.7
E3-3-M5-04/BK	Reverse stitch	11#	1	3	/	4	4.6	0.7-2	5.5	5500	495x355x545	27.6/36.7
E3-4-M5-23/BK	Reverse stitch	11#	2	4	2	3	4.6	0.7-2	5.5	5500	495x355x545	27.6/36.7
E3-4-M2-24	Plain seaming	11#	2	4	2	4	4.6	0.7-2	5.5	5500	495x355x545	27.6/36.7
E3-5-M2-35	Plain seaming	14#	2	5	3	5	4.6	0.7-2	5	5500	495x355x545	28.1/37.1
E3-5-M2-55	Heavy duty	14#	2	5	5	5	4.6	0.7-2	5	5500	495x355x545	28.1/37.1
E3-5x2-56	Extra Heavy Duty	19#	2	5	5	6	5	0.7-2	5	5500	495x355x545	28.1/37.1

E4S

Light And Heavy Adjustable Power Saving Overlock Machine

Light And Heavy Adjustable Freely, Quick Response For Start And Brake



Suitable for clothing items such as

T-shirts, underwears, casual jeans and other middle and high-level clothes

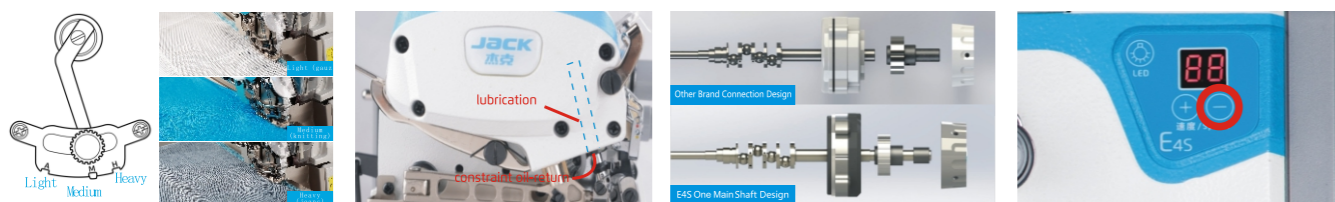

One machine to sew different kinds of fabrics.

Needle bar avoid oil-leakage, clean sewing.

One main shaft design, stable and fast.

One key reset, easy learn and use.

Model	Functions	Needle	Needle No.	Thread No.	Needle Distance (mm)	Stitch Width (mm)	Stitch Length (mm)	Differential Ratio	Presser Foot Lifting Height (mm)	Max. Speed (s.p.m)	Volume (mm)	Weight (kg)
E4S-2	Fabric Joint Seaming	DCx27 11#	1	2	-	6	4	0.7-2	3.5	5500	525x360x510	28/36
E4S-02x250	Pocket Binding Seaming	DCx27 14#	2	4	5	-	4	0.7-2	3.5	5500	525x360x510	28/36
E4S-3-02/233	Plain Seaming	DCx27 11#	1	3	-	4	4	0.7-2	5	5500	525x360x510	28/36
E4S-3-82/233	Back Latching	DCx27 11#	1	3	-	4	4	0.7-2	5	5500	525x360x510	28/36
E4S-3-32R2/223	Narrow Sewing	DCx27 9#	1	3	-	1.5	4	0.7-2	5	5500	525x360x510	28/36
E4SWF-3-02/213	Non-woven Material	DCx27 14#	1	3	-	4	8.5	-	5.5	5500	525x360x510	28/36
E4S-4-M03/333	Plain Seaming	DCx27 11#	2	4	2	4	4.6	0.7-2	5.5	5500	525x360x510	28/36
E4S-4-83/323	Back Latching	DCx27 11#	2	4	2	4	4.6	0.7-2	5.5	5500	525x360x510	28/36
E4S-4-M03/333/H/M	Heavy Duty	DCx27 11#	2	4	2	4	4.6	0.7-2	6	5500	525x360x510	28/36
E4SMJ-4-53/233	Towel Ending	DCx27 11#	2	4	2	4	4	0.7-2	5	5500	525x360x510	28/36
E4S-5-53/233	Tape Attaching Seaming	DCx27 14#	2	5	3	5	4	0.7-2	5	5500	525x360x510	28/36
E4S-5-02A/233	Light material	DCx27 11#	2	5	3	4	4	0.7-2	5	5500	525x360x510	28/36
E4S-5-03/233	5x5 Stitch	DCx27 14#	2	5	5	5	4	0.7-2	5	5500	525x360x510	28/36
E4S-5-03/333	3x4 Stitch	DCx27 14#	2	5	3	4	4	0.7-2	5	5500	525x360x510	28/36
E4S-5-A04/435	Especially For Denim	DCx27 19#	2	5	5	6	5	0.8-1.5	7	5500	525x360x510	28/36
E4S-5-M04/435	Extra Heavy Duty	DCx27 19#	2	5	5	6	5	0.8-1.5	7	5500	525x360x510	28/36
E4S-6-03/333	Plain Seaming	DCx27 11#	3	6	3x2	4	4	0.7-2	5	5500	525x360x510	28/36
E4S-6-M04/435	Especially For Denim	DCx27 19#	3	6	5x2.5	3.5	5	0.8-1.5	7	5500	525x360x510	28/36

Note:H/M suitable for light and heavy; optional device KS (vertical suction device) and KH(horizontal suction device); machine volume:525*360*630(mm), weight 28/39(kg)

JK-797TDI-4/KS/FR01

Small Cylinder-bed Variable Top Feed Super Fast Overlock Machine

High Efficiency, Wide Use, No Dislocation

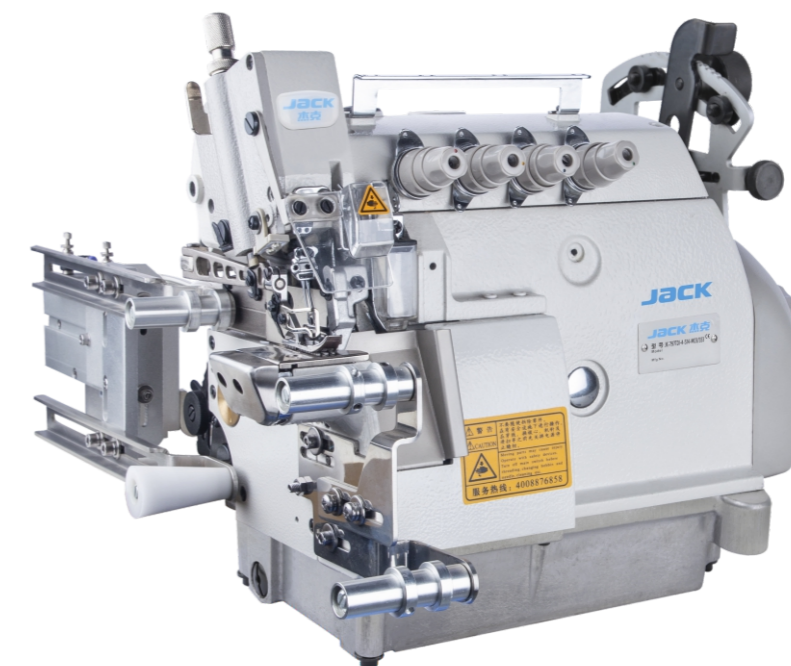

Suitable for clothing items such as

T-shirts, underwears, casual jeans and other middle and high-level clothes



Small cylinder bed, flexible operation

Tod differential device, strong fabric feeding

Power-saving, long life

Stitch length adjust, high-efficiency and convenient

Model	Functions	Needle	Needle No.	Thread No.	Needle Distance (mm)	Stitch Width (mm)	Stitch Length (mm)	Differential Ratio	Presser Foot Lifting Height (mm)	Max. Speed (s.p.m)	Volume (mm)	Weight (kg)
JK-797TDI-3-504-02/233N	basic sewing	DCx27 11#	1	3	-	4	3.8	0.8-1.8	5	7000	525X360X510	28/36
JK-797TDI-4-514-M03/333	basic sewing	DCx27 11#	2	4	2	4	3.8	0.8-1.8	5.5	7000	525X360X510	28/36
JK-797TDI-4-514-M03/333/FR01	pneumatic distraction	DCx27 11#	2	4	2	4	3.8	0.8-1.8	5.5	7000	525X360X630	28/36
JK-797TDI-4-514-M03/333/FR02	mechanic distraction	DCx27 11#	2	4	2	4	3.8	0.8-1.8	5.5	7000	525X360X630	28/40
JK-797TDI-4-514-M03/333/KS/FR01	pneumatic distraction, suction and trimming	DCx27 11#	2	4	2	4	3.8	0.8-1.8	5.5	7000	525X360X630	28/39
JK-797TDI-4-514-M03/333/KS/FR02	mechanic distraction, suction and trimming	DCx27 11#	2	4	2	4	3.8	0.8-1.8	5.5	7000	525X360X630	28/43
JK-797TDI-4-514-M03/333/KS/FR06	Auto alignment, suction and trimming(Solenoid valve)	DCx27 11#	2	4	2	4	3.8	0.8-1.8	5.5	7000	525X360X630	28/43
JK-797TDI-4-514-M03/333/KS/FR09	Full auto feeding, suction and trimming	DCx27 11#	2	4	2	4	3.8	0.8-1.8	5.5	7000	525X360X630	28/43

Note: 1. Small cylinder-bed super fast overlock machine JK-797DI series parameter is same as above;
2. KS means side suction trimming, FR01 means elastic auto distraction device, FR02 means elastic mechanic distraction device.
3. FR06 means pneumatic distraction device, auto alignment(Solenoid valve); FR09 means pneumatic distraction device, auto feeding, auto alignment(Solenoid valve).

Overlock Process Device

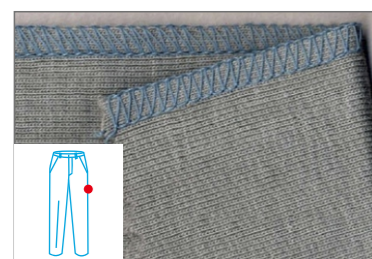

Three Threads Basic Stitch
C6-3-02/233/KS



Three Threads Condense Seaming
C6-3-32R2/223/KS



Three Threads Condense Seaming
C6-3-12/233/KS



Pocket Binding Seaming
C6-02X250/AT

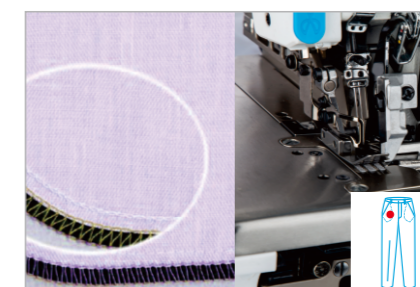

Tape Attaching Seaming
C6-5-53/233/AT



Towel Ending
C6-MJ-4-53/233/AT

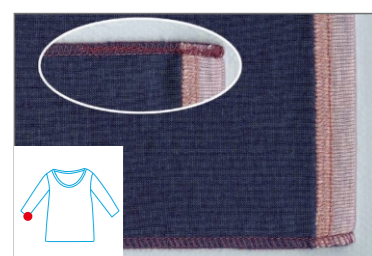

Three Threads Pneumatic Back Latch Seaming
C6-3-82/233/BK



Four Threads Basic Stitch
C6-4-M03/333/KS



Four Threads Patch Seam (shoulder strap presser foot)
C6-4-M03/333/AT



Non-woven Material
C6-WF-3-02/213/AT

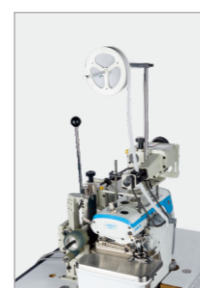

Rear Puller + Elastic Attaching Device



Rear Puller



Elastic Attaching Device

Note:
KS: Vertical suction device
KH: Horizontal device
AT: Pneumatic cutter trimming



Four Threads Pneumatic BackLatch Seaming
C6-4-83/323/BK

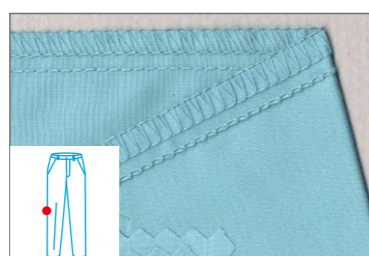

Five Threads Basic Stitch (3X4)
C6-5-03/333/KH

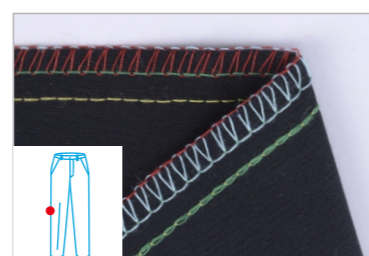

Five Threads Basic Stitch(5x5)
C6-03/233/KH



FR01 Pneumatic Extension Device

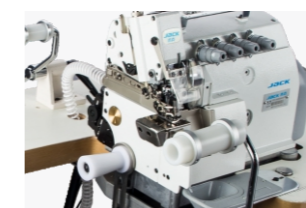

FR02 Mechanical Extension Device



FR06 Automatic Position Adjustment, Pneumatic Extension Device



FR09 Fully Automatic Feeding, Position Adjustment, Pneumatic Extension Device

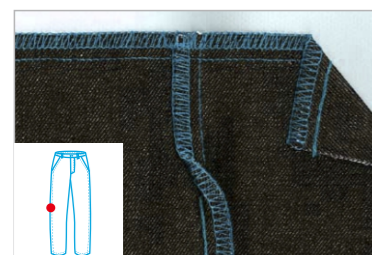

Five Threads Heavy Duty Stitch
C6-5-M04/435/AT

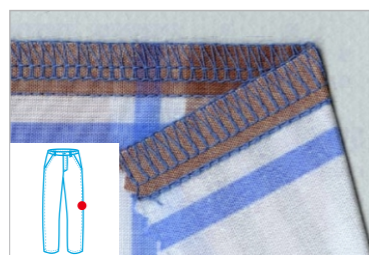

Six Threads Basic Stitch
C6-6-03/333/AT



Six Threads Denim Stitch
C6-6-M04/435/AT

K6 Super Fast Intelligent Interlock Machine

Super High Speed, Step Motor Driving, Anti Wrinkle

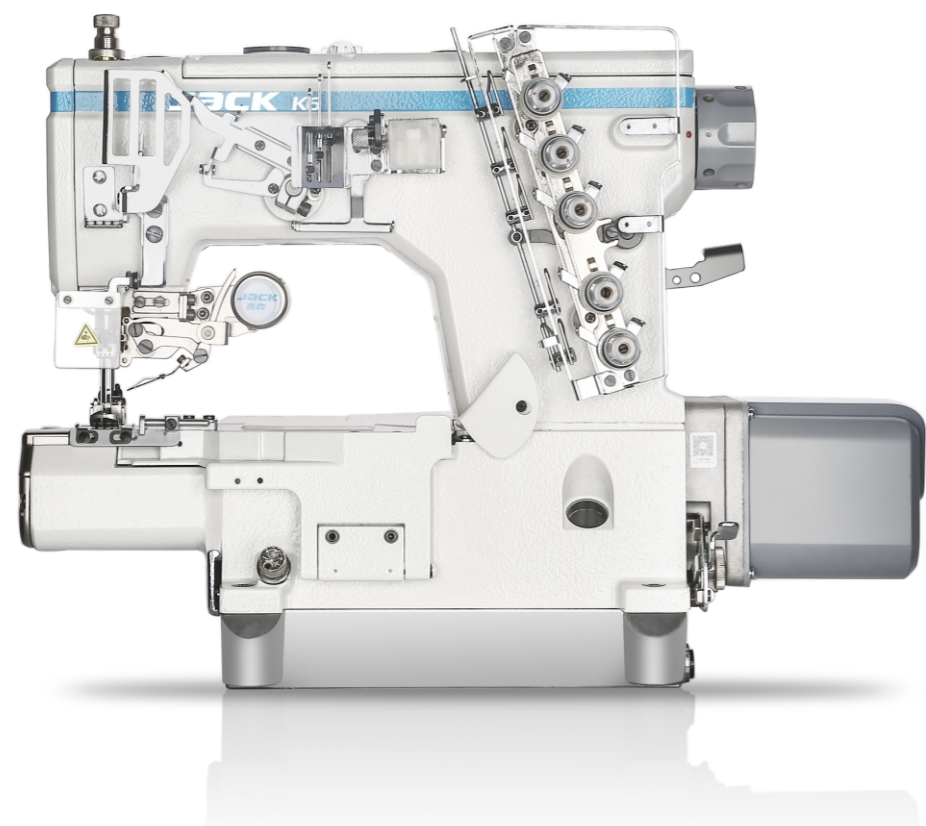

Suitable for clothing items such as T-shirts, underwears, casual jeans and other middle and high-level clothes

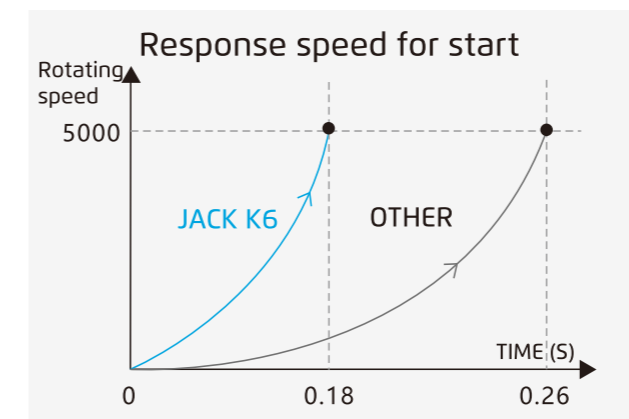

➤ Super high speed, double production

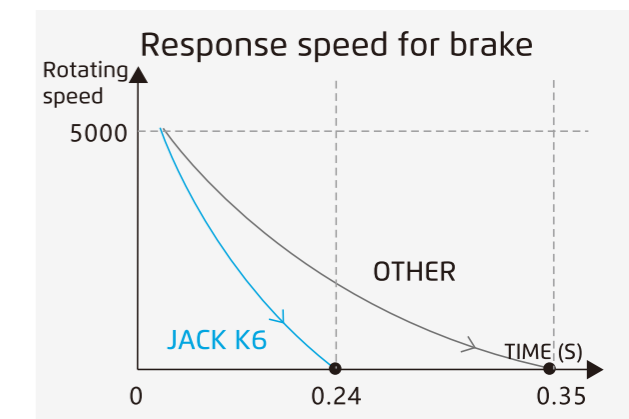

➤ Step motor driving, stable and quiet



➤ Convenient for material putting and feeding, First choice for tabe binding craft

Model	Needle Size	Needle Number	Thread Number	Needle Distance (mm)	Stitch Width (mm)	Differential Ratio	Foot Height (mm)	Default Speed (S.p.m)	Max Speed (S.p.m)	Step Motor Driving	Top Thread Trimmer	Thread Wipping	Volume (mm)	Weight (kg)
K6-UT-01GB (Plain Seaming)	11#/14#	3	5	1.5-4.5	5.6/6.4	0.6-1.3	0.6-1.3	7	5500	✓	✓	Optional	675*450*602	48/58
K6-UT2-01GB (Plain Seaming)	11#/14#	3	5	1.5-4.5	5.6/6.4	0.6-1.3	0.6-1.3	7	5500	✓		✓	675*450*602	48/58
K6-UT-02BB (Tape Binding)	11#/14#	3	5	1.5-4.5	5.6/6.4	0.6-1.3	0.6-1.3	6	5500	✓	✓	Optional	675*450*602	48/58
K6-UT2-02BB (Tape Binding)	11#/14#	3	5	1.5-4.5	5.6/6.4	0.6-1.3	0.6-1.3	6	5500	✓		✓	675*450*602	48/58
K6-UT-03GB (Covering Stitch for one side)	11#/14#	3	5	1.5-4.5	5.6/6.4	0.6-1.3	0.6-1.3	7	5500	✓	✓	Optional	675*450*602	48/58
K6-UT2-03GB (Covering Stitch for one side)	11#/14#	3	5	1.5-4.5	5.6/6.4	0.6-1.3	0.6-1.3	7	5500	✓		✓	675*450*602	48/58
K6-UT-08AC (Bottom Hemming)	11#/14#	3	5	1.5-4.5	5.6/6.4	0.6-1.3	0.6-1.3	7	5500	✓	✓	Optional	675*450*602	48/58
K6-UT2-08AC (Bottom Hemming)	11#/14#	3	5	1.5-4.5	5.6/6.4	0.6-1.3	0.6-1.3	7	5500	✓		✓	675*450*602	48/58

Notice: Top thread trimmer is not available in UT2 model.

K5E Large Operation Space Computerized Lockstitch Machine

Low Sound, High Efficiency, Stable Performance

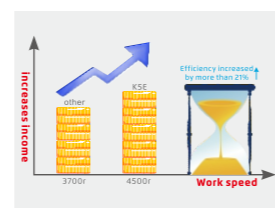

High speed, high efficiency



Wide adaptability of fabric



One-key reset, easy operation

Suitable for clothing items such as

shirts, suits, pants, down jackets, etc.

Model	Needle	Needle No.	Thread No.	Stitch Width (mm)	Stitch Length (mm)	Differential Ratio	Presser Foot Lifting Height (mm)	Max. Speed (s.p.m)	Volume (mm)	Weight (kg)
K5E-UT-01GB	UY128GAS 11-14#	3	5	1.5-4.5	5.6/6.4	0.8-1.3	7	5500	670×445×595	52/62
K5E-UT-02BB	UY128GAS 11-14#	3	5	1.5-4.5	5.6/6.4	0.8-1.3	7	5500	670×445×595	52/62
K5E-UT-03GB	UY128GAS 11-14#	3	5	1.5-4.5	5.6/6.4	0.8-1.3	7	5500	670×445×595	52/62
K5E-UT-08AC	UY128GAS 11-14#	3	5	1.5-4.5	5.6/6.4	0.8-1.3	7	5500	670×445×595	52/62
K5E-UT-35AC	UY128GAS 11-14#	3	5	1.5-4.5	5.6/6.4	0.8-1.3	7	5000	670×445×720	53/65

Note: 1.UT2: computerized machine, standard: with thread wiper, without upper thread trimmer D: direct drive.

JK-8770-01GX356/UT

High Speed Computerized Small Cylinder-bed Interlock Machine

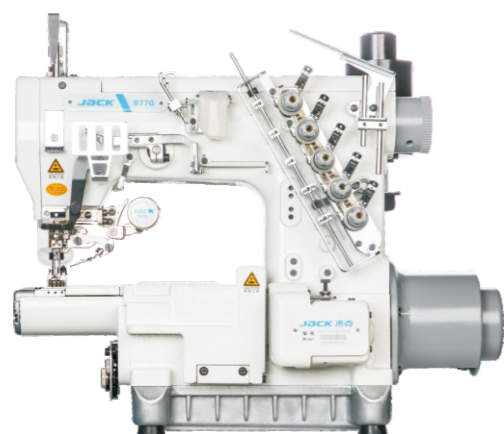

Front-mounted bobbin thread distribution reel



Mini direct drive servo motor

Suitable for clothing items such as

shirts, suits, pants, down jackets, etc.

Model	Stitch	Thread	Stitch Length	Stitch Width (mm)	Presser Foot Height(mm)	Differential Ratio	Speed (S.p.m)	Optional Device
JK-8770-01GX356/UT	3	5	1.4-4.5	5.6	7	0.8-1.4	4200	D UT
JK-8770-01GX364/UT	3	5	1.4-4.5	6.4	7	0.8-1.4	4200	UT2 UTL

W4 High Speed Computerized Flat-bed Interlock Machine

Full-automatic; Multifunctional; Stable



Suitable for clothing items such as

T-shirts, underwears, casual jeans and other middle and high-level clothes



Automatic thread trimmer, Enhance operation efficiency

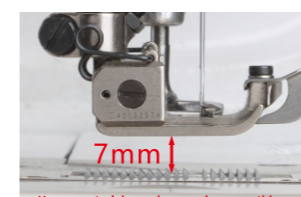
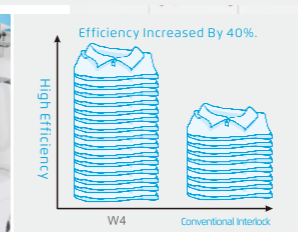

Heavy materials can be sewn smoothly
Height of presser foot form 5mm up to 7mm



For light and heavy fabric, beautiful stitch

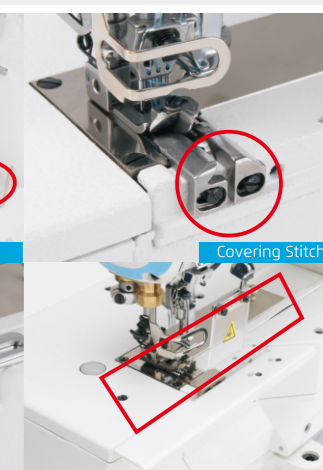

Bottom Hemming

Plain Seaming

One Machine Multi-functions, Wide Application

Model	Functions	Needle	Needle No.	Thread No.	Stitch Length (mm)	Stitch Width (mm)	Differential Ratio	Presser Foot Lifting Height (mm)	Max. Speed (s.p.m)	Volume (mm)	Weight (kg)
W4-UT2-01GB	Plain Seaming	UY128GAS 11-14#	3	5	1.5-4.5	5.6/6.4	0.65-1.3	7	5500	670×445×595	54/64
W4-UT2-02BB	Tape Binding	UY128GAS 11-14#	3	5	1.5-4.5	5.6/6.4	0.65-1.3	6	5500	670×445×595	54/64
W4-UT2-03DB	Covering Stitch	UY128GAS 11-14#	3	5	1.5-4.5	5.6/6.4	0.65-1.3	7	5500	670×445×595	54/64
W4-UT2-08AC	Bottom Hemming	UY128GAS 11-14#	3	5	1.5-4.5	5.6/6.4	0.65-1.3	7	5500	670×445×595	54/64
W4-D-01GB	Plain Seaming	UY128GAS 11-14#	3	5	1.5-4.5	5.6/6.4	0.65-1.3	7	5500	670×445×595	48/58
W4-D-02BB	Tape Binding	UY128GAS 11-14#	3	5	1.5-4.5	5.6/6.4	0.65-1.3	6	5500	670×445×595	48/58
W4-D-03DB	Covering Stitch	UY128GAS 11-14#	3	5	1.5-4.5	5.6/6.4	0.65-1.3	7	5500	670×445×595	48/58
W4-D-05CB	Elastic Lace Attaching (Right-Side Cutter)	UY128GAS 11-14#	3	5	1.5-4.5	5.6/6.4	0.65-1.3	6	4000	670×445×595	48/58
W4-D-08AC	Bottom Hemming	UY128GAS 11-14#	3	5	1.5-4.5	5.6/6.4	0.65-1.3	7	5500	670×445×595	48/58
W4-D-23GBL	Plain Seaming (Extra Large Stitch Length)	UY128GAS 11-14#	2	4	7-7.5	5.6/6.4	1	7	4000	670×445×595	48/58
W4-D-23BBL	Tape Binding (Extra Large Stitch Length)	UY128GAS 11-14#	2	4	7-7.5	5.6/6.4	1	7	4000	670×445×595	48/58

Note: 1.UT2: computerized machine, standard with thread wiper, without upper thread trimmer D:direct drive
2.UT type computerized machine is optional, standard with thread wiper and upper thread trimmer: UTL pneumatic type computerized is optional.

JK-8670BDII/UT High Speed Computerized Small Cylinder-bed Interlock Machine

Small Cylinder, Convenient, High Efficiency



Suitable for clothing items such as

T-shirts, underwears, casual jeans and other middle and high-level clothes

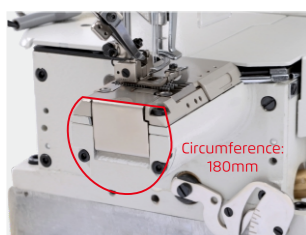

Circumference: 180mm

Small cylinder 180mm



Auto thread trimming

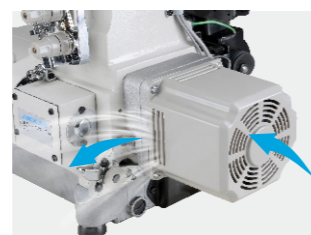

Cooling fan

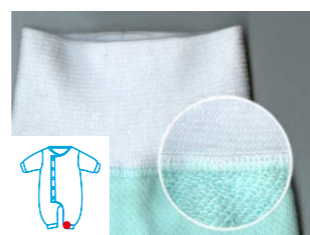

Suitable for small cylinder garment sewing

Model	Functions	Needle	Needle No.	Thread No.	Stitch Length (mm)	Stitch Width (mm)	Differential Ratio	Presser Foot Lifting Height (mm)	Max. Speed (S.p.m)	Volume (mm)	Weight (kg)
JK-8670BDII-01CB/UT	Plain Seaming	UY128GAS 11-14#	3	5	1.5-3.6	5.6/6.4	0.8-1.4	6.2	4500	680×420×630	50/60
JK-8670BDII-03FB/UT	Covering Stitch(Flattening out)	UY128GAS 11-14#	3	5	1.5-3.6	5.6/6.4	0.8-1.4	6.2	4500	680×420×630	50/60
JK-8670BDII-03GB/UT	Covering Stitch(Folding over)	UY128GAS 11-14#	3	5	1.5-3.6	5.6/6.4	0.8-1.4	6.2	4500	680×420×630	50/60
JK-8670BDII-08AC/UT	Bottom Hemming(Narrow)	UY128GAS 11-14#	3	5	1.5-3.6	5.6/6.4	0.8-1.4	6.2	4500	680×420×630	50/60
JK-8670BDII-08BC/UT	Bottom Hemming(Wide)	UY128GAS 11-14#	3	5	1.5-3.6	5.6/6.4	0.8-1.4	6.2	4500	680×420×630	50/60
JK-8670BDI-01CB	Plain Seaming	UY128GAS 11-14#	3	5	1.5-3.6	5.6/6.4	0.8-1.4	6.2	4500	630×390×630	42/54
JK-8670BDI-03FB	Covering Stitch	UY128GAS 11-14#	3	5	1.5-3.6	5.6/6.4	0.8-1.4	6.2	4500	630×390×630	42/54
JK-8670BDI-03GB	Covering Stitch	UY128GAS 11-14#	3	5	1.5-3.6	5.6/6.4	0.8-1.4	6.2	4500	630×390×630	42/54
JK-8670BDI-08AC	Bottom Hemming(Narrow)	UY128GAS 11-14#	3	5	1.5-3.6	5.6/6.4	0.8-1.4	6.2	4500	630×390×630	42/54
JK-8670BDI-08BC	Bottom Hemming(Wide)	UY128GAS 11-14#	3	5	1.5-3.6	5.6/6.4	0.8-1.4	6.2	4500	630×390×630	42/54

JK-8009VCDII/UTL High Speed Computerized Multi-needle Machine

Convenient Operation, Laborsaving, High Efficiency

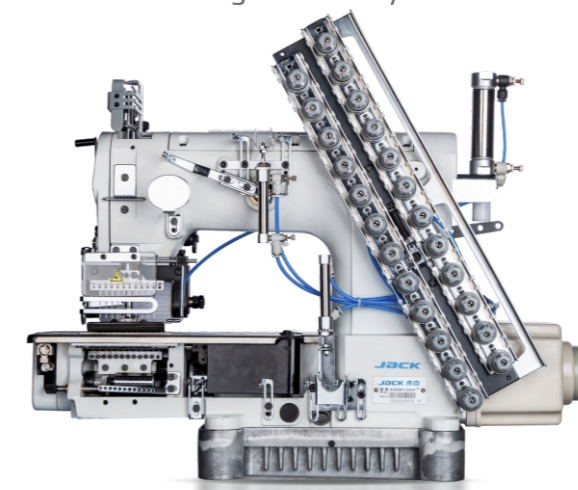

Suitable for clothing items such as

T-shirts, underwears, casual jeans and other middle and high-level clothes



Elastic attaching



Shirt-fronting

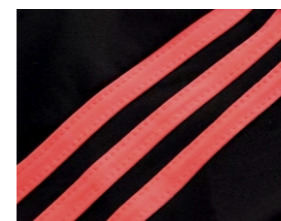

Tape attaching



Waist band JK-8009HF

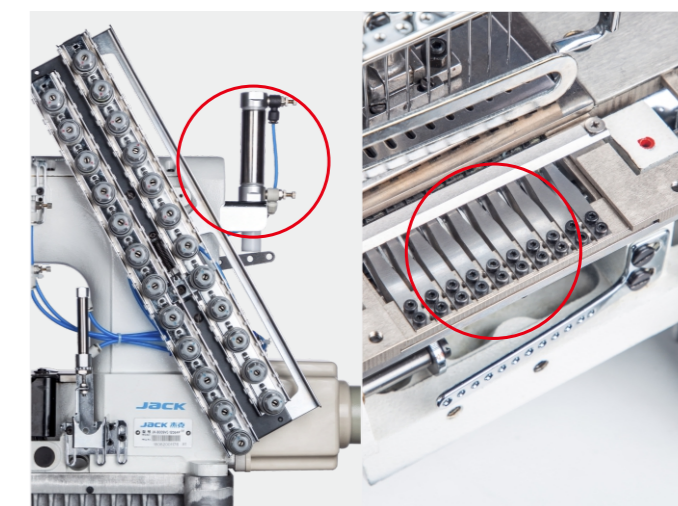

Auto presser foot lifter, more laborsaving, auto trimming, higher efficiency

Model	Needle	Needle No.	Thread No.	Stitch Length (mm)	Stitch Width (mm)	Presser Foot Lifting Height (mm)	Max. Speed (S.p.m)	Volume (mm)	Weight (kg)
JK-8009VCD I I-04064P/04080P/04085P/04095P/UTL	UO113 14-16#	4	8	1.7-4.0	6.4/7.9/8.7/9.5	8	3500	615×400×605	52.5/57.5
JK-8009VCDI I -06048P /06064P/06080P/06095P/UTL	UO113 14-16#	6	12	1.7-4.0	6.4/7.9/9.5	8	3500	615×400×605	52.5/57.5
JK-8009VCDI I -08064P/08085P/UTL	UO113 14-16#	8	16	1.7-4.0	6.4/8.7	8	3500	615×400×605	52.5/57.5
JK-8009VCDI I -12064P /UTL	UO113 14-16#	12	24	1.7-4.0	6.4	8	3500	615×400×605	52.5/57.5
JK-8009VCDI I -13064-32P /UTL	UO113 14-16#	13	26	1.7-4.0	6.4	8	3500	615×400×605	52.5/57.5
JK-8009HF-04064-254P	TVx5 19-21#	4	8	1.7-4.0	6.4-25.4-6.4	8	3500	615×400×605	52.5/57.5
JK-8009VCD I -04064P/04080P/04085P/04095P	UO113 14-16#	4	8	1.7-4.0	6.4/7.9/8.7/9.5	8	3500	615×400×605	52.5/57.5
JK-8009VCD I -06048P /06064P/06080P/06095P	UO113 14-16#	6	12	1.7-4.0	4.8/6.4/7.9/9.5	8	3500	615×400×605	52.5/57.5
JK-8009VCD I -08032P/08048P/08064P/08085P	UO113 14-16#	8	16	1.7-4.0	3.2/4.8/6.4/8.7	8	3500	615×400×605	52.5/57.5
JK-8009VCD I -12032P/12048P /12064P	UO113 14-16#	12	24	1.7-4.0	3.2/4.8/6.4	8	3500	615×400×605	52.5/57.5
JK-8009VCD I -13064-32P	UO113 14-16#	13	26	1.7-4.0	6.4-3.2	8	3500	615×400×605	52.5/57.5
JK-8009VCD I -17032P	UO113 14-16#	17	34	1.7-4.0	3.2	8	3500	615×400×605	52.5/57.5
JK-8009VCD I -23032P	UO113 14-16#	23	46	1.7-4.0	3.2	8	3500	615×400×605	52.5/57.5
JK-8009VCD I -25032P	UO113 14-16#	25	50	1.7-4.0	3.2	8	3500	615×400×605	52.5/57.5

Note: 1. UTL means computerized; 2. optional additional device: P(dentiform puller), PR(smooth puller), VWL(front elastic feeding device), VPL(tape attaching sewing), VSF(placket sewing), VPQ(elastic wrinkled sewing). Optional needle gauge: 4 needles[1/4(6.4), 5/16(7.9), 11/32(8.7),3/8(9.5)]; 6 needles[3/16(4.8), 1/4(6.4), 5/16(7.9), 3/8(9.5)]; 8 needles 1/8(3.2), 3/16(4.8), 1/4(6.4), 11/32(8.7)]; 12 needles [1/8(3.2); 3/16(4.8); 1/4(6.4)]; 13needles [1/8(3.2), 1/4(6.4)].

JK-8740-460-02/D/AW/S

4 Needles 6 Thread Feed-off-arm Interlock Machine

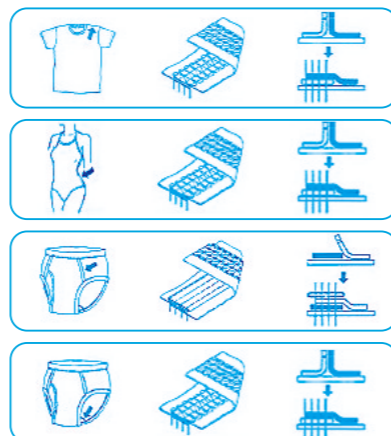
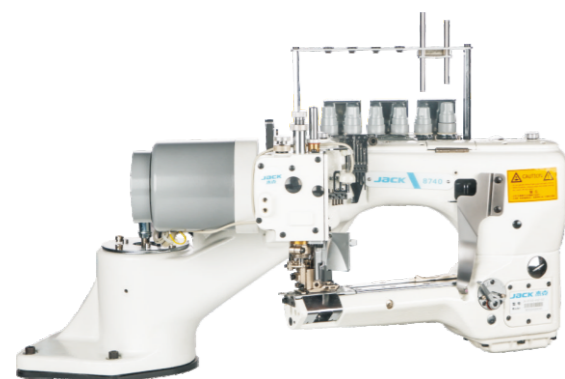

Suitable for clothing items such as

shirts, suits, pants, down jackets, etc.

Large operating space design. The patented new innovative machine seat design provides a large workbench operating space for sewing, which is more conducive to the sewing of large fabrics and improves work efficiency and sewing effects.

Model	Needles	Stitches	Stitch Width (mm)	Stitch Length (mm)	Differential Ratio	Presser Foot Height(mm)	Needle Distance(mm)	Speed (S.p.m)	Optional device	Suction device	Sewing function
JK-8740-01	4	6	4.8 5.2	1.6-2.5	1:0.7-1:0.5	6-8	30	3200	D	AW1L	S
JK-8740-02	4	6	6.0 6.4	1.6-2.5	1:0.7-1:0.5	6-8	30	3200	UT	AW1S	DS
JK-8740-02H	4	6	7.0 8.0	1.6-2.5	1:0.7-1:0.5	6-8	30	3200	UTL	AW2L AW2S	T1 T2

JK-8787-01GX356/UT

Super High Speed Computerized Cylinder-bed Interlock Machine

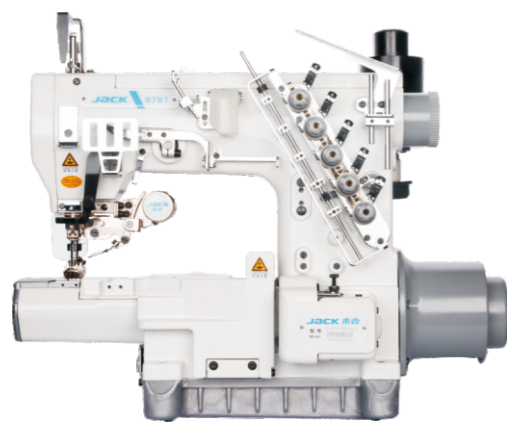

Double Needle Feed-off-arm Machine



electromagnetic direct drive presser foot lifter group

Suitable for clothing items such as

shirts, suits, pants, down jackets, etc.

Model	Stitch	Thread	Stitch Length	Stitch Width (mm)	Presser foot Height(mm)	Differential Ration	Speed (S.p.m)	Optional Device	Pulley
JK-8787-01GX356/UT	3	5	1.4-4.5	5.6	7	0.8-1.4	4500		
JK-8787-01GX364/UT	3	5	1.4-4.5	6.4	7	0.8-1.4	4500	D	
JK-8787-02BX356/D	3	5	1.4-4.5	5.6	7	0.8-1.4	4500	UT	PL(gear wheel)
JK-8787-02BX364/D	3	5	1.4-4.5	6.4	7	0.8-1.4	4500	UT2	PR(Flat wheel)
JK-8787-35ACX356 /UT	3	5	1.4-4.5	5.6	7	0.8-1.4	4500	UTL	
JK-8787-35ACX364 /UT	3	5	1.4-4.5	6.4	7	0.8-1.4	4500		

Remarks: D is a direct drive sewing machine, UT is a computerized, optional is UT2 (without thread cutter)

JK-1500-UT

High Speed Feed-Up-The Arm, Cylinder Bed Interlock Machine

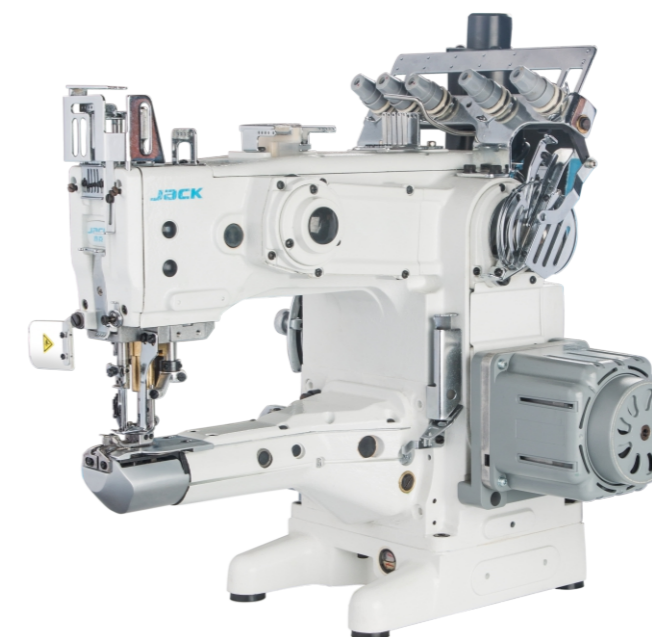

Suitable for clothing items such as

shirts, suits, pants, down jackets, etc.



Auto trimmer & auto foot lifter, higher efficiency



Adapt to heavy and light material, out put perfect stitch



One single machine for multipurpose, suitable for variety of crafts



Large space, convenient for operating

Model	Needle Size	Thread Number	Needle Number	Needle Distance	Differential Ratio	Foot height	Needle bar Stroke	Defalut Speed (S.p.m)	Max Speed (S.p.m)	Auto trimmer	Cover seaming	Bottom hemming	Volume (mm ³)	Weight (kg)
JK-1500-M	#9-#16	5	3	1.2-4	1: 0.8-1: 2	8	31.5	3500	4000	x	√	√	62×47×67	43/52
JK-1500-M-D	#9-#16	5	3	1.2-4	1: 0.8-1: 2	8	31.5	3500	4000	x	√	√	62×47×67	43/52
JK-1500-L	#9-#16	5	3	1.2-4	1: 0.8-1: 2	8	31.5	3500	4000	x	√	√	70×25×65	45/55
JK-1500-L-D	#9-#16	5	3	1.2-4	1: 0.8-1: 2	8	31.5	3500	4000	x	√	√	70×25×65	48/58
JK-1500-M-UT	#9-#16	5	3	1.2-4	1: 0.8-1: 2	8	31.5	3500	4000	√	√	√	61×53×65	52/62
JK-1500-M-UT-T	#9-#16	5	3	1.2-4	1: 0.8-1: 2	8	31.5	3500	4000	√	√	√	61×53×65	52/62
JK-1500-L-UT-H	#9-#16	5	3	1.2-4	1: 0.8-1: 2	8	31.5	3500	4000	√	√	√	70×53×65	55/68
JK-1500-L-UT-T	#9-#16	5	3	1.2-4	1: 0.8-1: 2	8	31.5	3500	4000	√	√	√	70×53×65	55/68
JK-1502-M	#9-#16	5	3	1.2-4	1: 0.8-1: 2	8	31.5	3500	4000	x	x	x	62×47×67	43/52
JK-1502-M-D	#9-#16	5	3	1.2-4	1: 0.8-1: 2	8	31.5	3500	4000	x	x	x	62×47×67	43/52
JK-1502-L	#9-#16	5	3	1.2-4	1: 0.8-1: 2	8	31.5	3500	4000	x	x	x	70×25×65	45/55
JK-1502-L-D	#9-#16	5	3	1.2-4	1: 0.8-1: 2	8	31.5	3500	4000	x	x	x	70×25×65	48/58
JK-1502-M-UT	#9-#16	5	3	1.2-4	1: 0.8-1: 2	8	31.5	3500	4000	√	x	x	61×53×65	52/62
JK-1502-M-UT-T	#9-#16	5	3	1.2-4	1: 0.8-1: 2	8	31.5	3500	4000	√	x	x	61×53×65	52/62
JK-1502-L-UT-H	#9-#16	5	3	1.2-4	1: 0.8-1: 2	8	31.5	3500	4000	√	x	x	70×53×65	55/68
JK-1502-L-UT-T	#9-#16	5	3	1.2-4	1: 0.8-1: 2	8	31.5	3500	4000	√	x	x	70×53×65	55/68

Notice: D stands for Direct driving model; UT stands for computerized model; L stands for extended cylinder bed model

Interlock Device and Stitches Table



Tape Binding

K5-UT-02BB

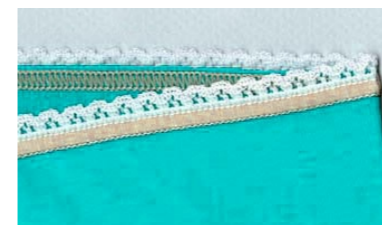

W4-D-05CB
Elastic Lace Attaching
(Right-side Cutter)



JK-8009VCDI/VPL
Tape Attaching

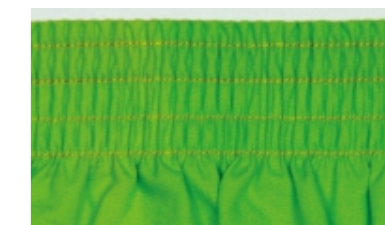

JK-8009VCDI/VWL
Elastic Attaching(Pants)



Covering Stitch

K5-D-03GB



JK-8009VCDI/VSF
Placket Seaming (Shirt)



JK-8009VCDI/VPQ
Simultaneous shirring



JK-8009HF
Waist Seaming (Jeans)



Bottom Hemming

K5-UT-08AC

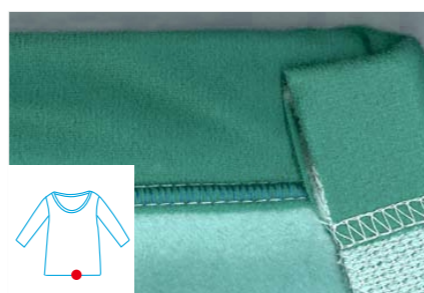

Device for Wide Sewing Bed



Four in One Sewing Bed

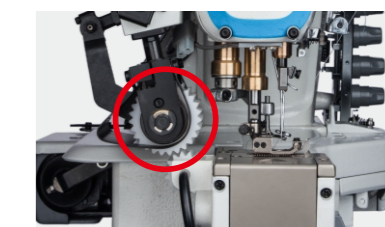

Rear Puller Device

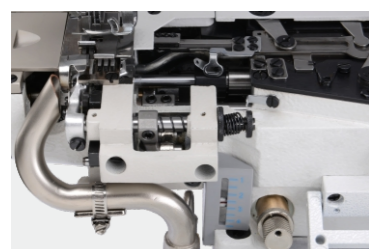

Bottom Hemming (Left-side Cutter)

K5-UT-35AC



MX-100A | Perfect Stitch Template Machine

No Reverse Seams, Perfect Quality

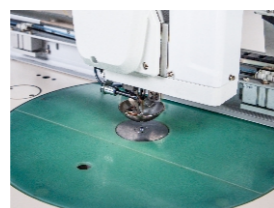

No Reverse Stitch, Perfect Quality



Super Large Sewing Area

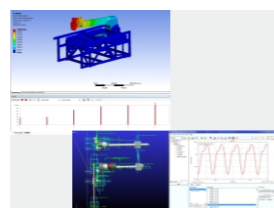

Low Noise, Low Vibration



Shifted Folding Table, Easy To Assemble&transfer

Model	Purpose	Needle	Needle No.	Thread No.	Sewing Area (mm)	Middle Presser Foot Height (mm)	Needle Gauge (mm)	Max.Speed (S.p.m)	Volume (mm)	Weight (kg)
MX-100A+-955SYX-F13 (Two directions screw drive)	Plate sewing	DPx5 DPx17	1	2	1400x950	15	1-12.7	2800	2350x1340x1535	742/845
MX-100A+-955TYX-F13 (One direction screw drive)	Plate sewing	DPx5 DPx17	1	2	1400x950	15	1-12.7	2800	2350x1340x1535	742/845

Note: standard IOT function; standard F13 bottom thread detection, Alternative device--F16: pointing device, F17: laser purifying device, F11A: laser cutting device, F11B: high power laser cutting device

MS-100A | Large Size Template Machine

Multi-process, Easy To Operate, Very Stable



Electronic Tension Post Function

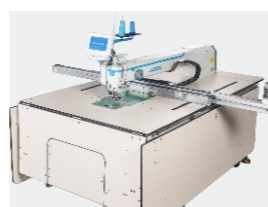

Shifted Folding Table, Easy To Assemble&transfer

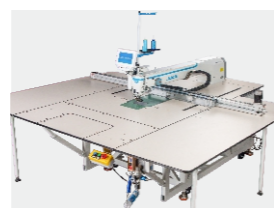

Super Large Sewing Area



Smart Plate Recognition, Save Power

Model	Purpose	Needle	Needle No.	Thread No.	Sewing Area (mm)	Middle Presser Foot Walking Distance (mm)	Needle Gauge (mm)	Max.Speed (S.p.m)	Volume (mm)	Weight (kg)
MS-100A+-955TYX-F13 (Big hook, One direction screw drive)	Plate sewing	DPx5 DPx17	1	2	1400x950	15	0.1-20	3000	2150x1310x1350	662/742
MS-100AP+-955TYX-F13 (Small hook, One direction screw drive)	Plate sewing	DPx5 DPx17	1	2	1400x950	15	0.1-20	3000	2150x1310x1350	662/742
MS-100A+-955SYX-F13 (Big hook, Double direction screw drive)	Plate sewing	DPx5 DPx17	1	2	1400x950	15	0.1-20	3000	2150x1310x1350	662/742
MS-100AP+-955SYX-F13 (Small hook, Double direction screw drive)	Plate sewing	DPx5 DPx17	1	2	1400x950	15	0.1-20	3000	2150x1310x1350	662/742

Note: standard IOT function; standard F13 bottom thread detection; Alternative device--F16: pointing device, F17: laser purifying device, F11A: laser cutting device, F11B: high power laser cutting device

MG-60A | Flexible Size Template Sewing Machine

Small Footprint, Wide Use, High Efficiency



Intelligent Middle Presser Foot, Beautiful Stitch



Double Moving Knife

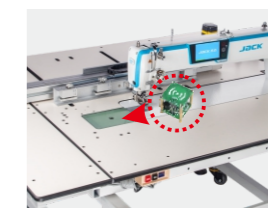

Flexible Size, Easy To Adapt Different Process



Quick hook changing windows

Model	Needle	Needle No.	Stitch length (mm)	Presser Foot Lifting Height (mm)	Max. Speed (s.p.m)	Sewing Range (mm)	Volume (mm)	Weight (kg)
MG-60A-40TSYX (Plain Seaming)	DBx1 7-14#	1	1-5	12	3300	600x400	1650x1420x1325	260/320

MG-80A | Intelligent Template Machine

Wide Use, Multiple Functions, High Efficiency, Easy To Place



Small Footprint



Humanized Operation Panel



Smart Middle Presser Foot, Perfect Sewing

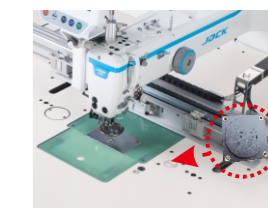

Higher Precision, Save Time& power

Model	Purpose	Needle	Needle No.	Thread No.	Sewing Area (mm)	Middle Presser Foot Height (mm)	Needle Gauge (mm)	Max.Speed (S.p.m)	Volume (mm)	Weight (kg)
MG-80AP-55TSYX	Plate sewing	DPx5 DPx17	1	2	800x550	15	1-5	3200	16200x1350x1305	320/395

Noted: IOT function is alternative, F13: bottom thread detection function, F16: pointing device, F17: laser purification device, F11A: laser cutting device

JK-T5878-68B/78B Automatic Pocket Welting Machine

Full-automatic, High Efficiency



Suitable for clothing items such as

shirts, suits, pants, down jackets, etc.



For different kinds of pocket



Automatic collective device

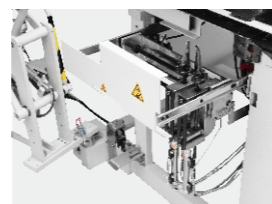

High output

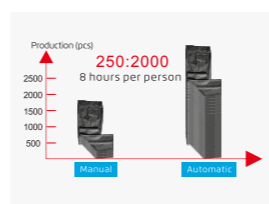

Easy to adjust, Precisely cutting

Model	Application	Needle	Stitch No.	Thread No.	Needle Gauge (mm)	Pocket Size (mm)	Max. Speed (s.p.m)	Volume (mm)	Weight (kg)
JK-T5878-68B	Straight Pocket	Mtx190 14#-18#	2	3	8-20	18-220	3000	1600×1100×1500	240/350
JK-T5878-78	Slant Pocket	DPx17 14#-18#	2	3	8-20	18-220	3000	1600×1100×1500	240/350

JK-T5878-58G Automatic Placket Setting Machine

Full-automatic, High Efficiency



Suitable for clothing items such as

shirts, suits, pants, down jackets, etc.

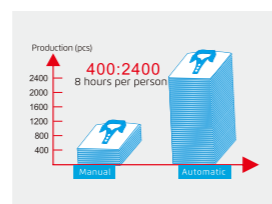

High output



For different kinds of placket



Automatic collective

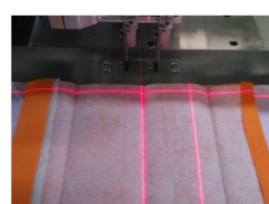

Laser positioning

Model	Application	Needle	Stitch No.	Thread No.	Sewing Width (mm)	Sewing Length (mm)	Max. Speed (s.p.m)	Volume (mm)	Weight (kg)
JK-T5878-58G	T-shirt Placket	DBX111#	1	2	1-50	15-260	4000	2050×1050×1580	258/350

JK-T9270D/9280D Direct Drive Feed-off-the Arm Machine

Mechatronic Widely Using



Automatic Needle stopping

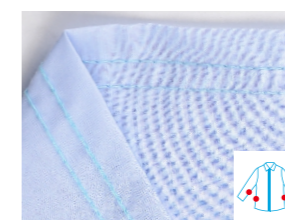

Double Needle Feed-off-arm Machine



Integrated, Power Saving

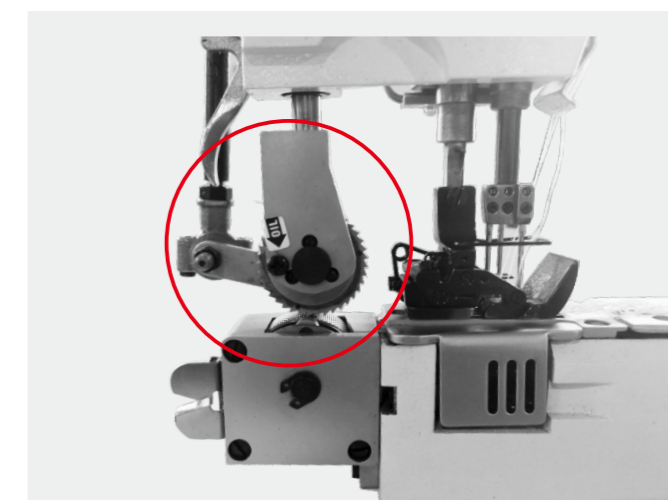

Rear Puller lubricated design

Model	Needle Gauge	Needle	Stitch No.	Thread No.	Needle Gauge (mm)	Presser Foot Lifting Height (mm)	Light Material	Medium Material	Heavy Duty	Heavier Duty	Max. Speed (mm)	Volume (mm)	Weight (kg)
JK-T9270D-12-Q	1/4,3/16	TV×64 12#	2	4	3.5	8	✓				3500	685×535×475	61.5/68.5
JK-T9270D-12-2PL-Q	1/4,3/16	TV×64 12#	2	4	3.5	8	✓				3500	685×535×475	61.5/68.5
JK-T9270D-12-2PS-Q	1/4,3/16	TV×64 12#	2	4	3.5	8	✓				3500	685×535×475	61.5/68.5
JK-T9270D-12-2PL-Q (for raincoat)	3/16	TV×64 12#	2	4	4.2	8	✓				3500	685×535×475	61.5/68.5
JK-T9270D-13-Q	1/8	TV×64 12#	3	6	3.5	8	✓				3500	685×535×475	61.5/68.5
JK-T9270D-13-2PL-Q	1/8	TV×64 12#	3	6	3.5	8	✓				3500	685×535×475	61.5/68.5
JK-T9270D-22-Q	1/4,3/16	TV×64 14#	2	4	3.5	8		✓			3500	685×535×475	61.5/68.5
JK-T9280D-53-Q	1/8	TV×5 21#	3	6	4.2	10			✓		3000	685×535×475	61.5/68.5
JK-T9280D-73-2PL-Q	1/8	TV×5 21#	3	6	4.2	10				✓	3000	685×535×475	61.5/68.5
JK-T9280D-73-PL-Q	1/8	TV×5 21#	3	6	4.2	10				✓	3000	685×535×475	61.5/68.5
JK-T9280D-73-PS-Q	1/8	TV×5 21#	3	6	4.2	10				✓	3000	685×535×475	61.5/68.5

Note: PL: rear puller; PS: box puller; JK-T9270D-12-2PL-Q needle gauge is 4.2mm for sewing raincoats.

JK-T1790G | Super Fast Computerized Button Hole Machine

Stable, Easy To Use And With High Efficiency



Suitable for clothing items such as

Keyhole seams for shirts, cardigans, work clothes, jeans, etc

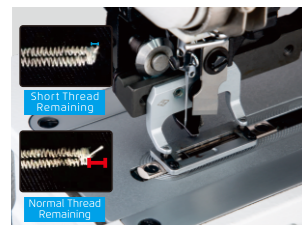

No need to trim the thread end Good knitting adaptation

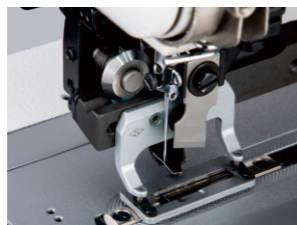

Intelligent system, high speed and high efficiency

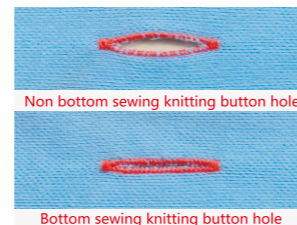

bottom sewing technology, nondeformable patterns

Model	Functions	Button Hole Size (mm)	Needle	Needle No.	Side Cutter Function	Thread No.	Parallel Interspace (mm)	Presser Foot Lifter Height (mm)	Max.Speed (S.p.m)	Volume (mm)	Weight (kg)
JK-T1790GS -1-D	Knits material	25×4	DP×5 12#	1	1/4"~3/4"	2	0.2-2.5	17	4200	66/78	880×390×635
JK-T1790GS -2-D	Knits material	35×5	DP×5 12#	1	1/4"~1"	2	0.2-2.5	17	4200	66/78	880×390×635
JK-T1790GS -3-D	Knits material	41×5	DP×5 12#	1	1/4"~11/4"	2	0.2-2.5	17	4200	66/78	880×390×635
JK-T1791GS -D	Knits material	70×5	DP×5 12#	1	1/4"~11/4"	2	0.2-2.5	17	4200	66/78	880×390×635
JK-T1792GS -D	Knits material	120×5	DP×5 12#	1	1/4"~11/4"	2	0.2-2.5	17	4200	66/78	880×390×635
JK-T1790GSX -1-D	Knits material	25×4	DP×5 12#	1	1/4"~3/4"	2	0.2-2.5	17	4200	66/78	880×390×635
JK-T1790GS -1-D-F13	Knits material	25×4	DP×5 12#	1	1/4"~3/4"	2	0.2-2.5	17	4200	66/78	880×390×635
JK-T1790GK -1-D	Knits material	25×4	DP×5KN 11#	1	1/4"~3/4"	2	0.2-2.5	17	4200	66/78	880×390×635
JK-T1790GS+ -1-D	Woven material	25×4	DP×5 12#	1	1/4"~3/4"	2	0.2-2.5	17	4200	66/78	880×390×635
JK-T1790GK -2-D	Woven material	35×5	DP×5KN 11#	1	1/4"~1"	2	0.2-2.5	17	4200	66/78	880×390×635
JK-T1790GK -3-D	Woven material	41×5	DP×5KN 11#	1	1/4"~11/4"	2	0.2-2.5	17	4200	66/78	880×390×635
JK-T1791GK -D	Woven material	70×5	DP×5KN 11#	1	1/4"~11/4"	2	0.2-2.5	17	4200	66/78	880×390×635
JK-T1792GK -D	Woven material	120×5	DP×5KN 11#	1	1/4"~11/4"	2	0.2-2.5	17	4200	66/78	880×390×635
JK-T1790GK -1-D-F13	Woven material	25×4	DP×5KN 11#	1	1/4"~3/4"	2	0.2-2.5	17	4200	66/78	880×390×635
JK-T1790GK+ -1-D	Woven material	25×4	DP×5KN 11#	1	1/4"~3/4"	2	0.2-2.5	17	4200	66/78	880×390×635

Noted:Standard with automatic lifting foot, automatic line cutting function; Short-end, Internet of Things and bottom line detection are optional functions

JK-T781G | New Integrated Electronic Lockstitch Buttonholing Machine

Auto Presser Foot Lifter, Power Saving Efficiency



Suitable for clothing items such as

Keyhole seams for shirts, cardigans, work clothes, jeans, etc



Power Saving And Efficient



Dot Screen, easy Operation



Short Thread Remaining, No Need Thread Timer Again



Wide Rang Of Applications, Beautiful Stitches

Model	Functions	Button Hole Size (mm)	Needle	Needle No.	Side Cutter Function	Thread No.	Parallel Interspace (mm)	Auto matic Thread Trimmer	Auto Presser Foot Lifter	Max.Speed (S.p.m)	Volume (mm)	Weight (kg)
JK-T781G-Z	Woven material	22×4	DP×5 12#	1	1/4"~3/4"	2	0.2-2.5	√	√	3600	730×365×695	46/66
JK-T782G-Z	Woven material	33×5	DP×5 12#	1	1/4"~1"	2	0.2-2.5	√	√	3600	730×365×695	46/66
JK-T783G-Z	Woven material	40×5	DP×5 12#	1	1/4"~1 1/4"	2	0.2-2.5	√	√	3600	730×365×695	46/66
JK-T781GK-Z	Knitting material	22×4	DP×5 11#	1	1/4"~3/4"	2	0.2-2.5	√	√	3600	730×365×695	46/66
JK-T781GX-Z	Woven material	22×4	DP×5 12#	1	1/4"~3/4"	2	0.2-2.5	√	√	3600	730×365×695	46/66
JK-T781G-Z-F13	Woven material	40×5	DP×5 12#	1	1/4"~3/4"	2	0.2-2.5	√	√	3600	730×365×695	46/66
JK-T782G-Z-F13	Woven material	33×5	DP×5 12#	1	1/4"~1"	2	0.2-2.5	√	√	3600	730×365×695	46/66
JK-T783G-Z-F13	Woven material	40×5	DP×5 12#	1	1/4"~1 1/4"	2	0.2-2.5	√	√	3600	730×365×695	46/66
JK-T781GK-Z-F13	Knitting material	22×4	DP×5 11#	1	1/4"~3/4"	2	0.2-2.5	√	√	3600	730×365×695	46/66
JK-T781GX-Z-F13	Woven material	22×4	DP×5 12#	1	1/4"~3/4"	2	0.2-2.5	√	√	3600	730×365×695	46/66

Noted:X stand for short thread and suitable for woven shirt thin material.F13 stand for bottom thread detection,need to be used air source

JK-T1900G

Multi-Function Computerized Bartack Machine

One Machine, Multi Functions, High efficiency, Short Thread Remaining

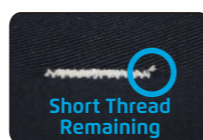
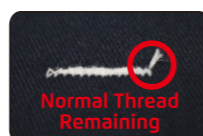

Suitable for clothing items such as

Shirts, jeans, non-woven bags, magic tape, shoes, bags, etc.

One machine with wide use, economic and useful



Bartack stitches



Bartacking

Cap hole

Small patterns

Fishing nets



Elastic joint

Cross bartack

Other bartack

Jeans pants loop

Socks

Part of bartack series patterns

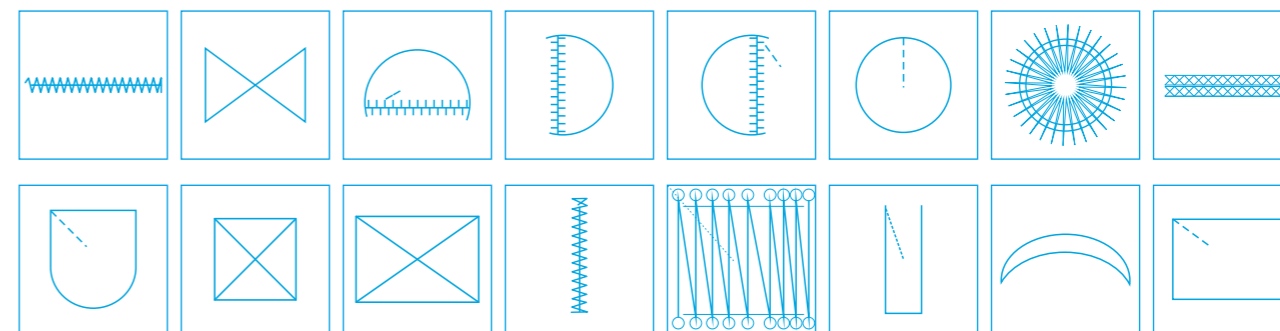

Part of button stitch series patterns

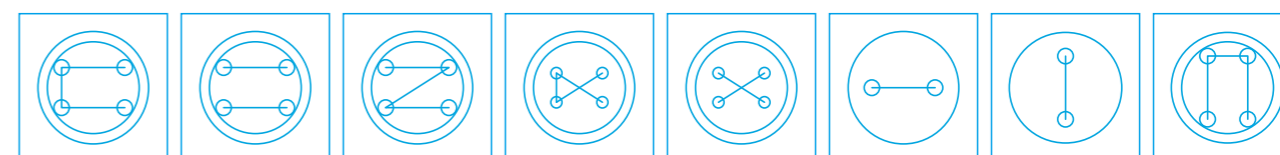

Bartack technical parameter

Model	Functions	Needle	Needle No.	Thread No.	Sewing range (X) (mm)	Sewing range (Y) (mm)	Presser Foot Lifting Height (mm)	Max.Speed (S.p.m)	Volume (mm)	Weight (kg)
JK-T1900GSK	Light and Middle Fabric	DPx5 16#	1	2	40	30	13	3200	805x405x525	55/64
JK-T1900GS	Light and Middle Fabric	DPx5 16#	1	2	40	30	13	3200	805x405x525	55/64
JK-T1900GHK	Heavy Fabric	DPx17 19#	1	2	40	30	13	2700	805x405x525	55/64
JK-T1900GH	Heavy Fabric	DPx17 19#	1	2	40	30	13	2700	805x405x525	55/64
JK-T1900GSXK	Short Thread Remaining	DPx5 16#	1	2	40	30	13	3200	805x405x525	55/64
JK-T1900GMK	Knitted Fabric	DPx5 11#	1	2	40	30	13	2700	805x405x525	55/64
JK-T1900GM	Knitted Fabric	DPx5 11#	1	2	40	30	13	2700	805x405x525	55/64
JK-T1900GY	Cap Hole	DPx5 16#	1	2	40	30	13	2700	805x405x525	55/64
JK-T1900GN	Fishing Net	DPx17 19#	1	2	40	30	13	2300	805x405x525	55/64
JK-T1900GL	Socks Sewing	DPx17 14#	1	2	40	35	13	2000	805x405x525	55/64
JK-T1906GS	Pattern	DPx17 14#	1	2	60	50	10	2700	805x405x525	58/67
JK-T1906GP	Elastic Attaching	DPx17 14#	1	2	60	50	10	2700	805x405x525	58/67

Note: Auto presser foot lifter, auto trimmer, auto wipper are standards. K:Bartacking and Button attaching can be transferred easily. X is short thread remaining.

Button stitch technical parameter

Model	Functions	Needle	Needle No.	Thread No.	Button diameter (mm)	Button size (mm)	Standard foot height (mm)	Max.Speed (S.p.m)	Volume (mm)	Weight (kg)
JK-T1903GSK	Pin buckle knot swaps	DPX17 14#	1	2	Φ8-Φ30	X:2.4-6.8 Y:2.4-6.8	10	2700	805x405x525	55/64
JK-T1903GR	Automatically send button	DPX17 14#	1	2	Φ9-Φ22	X:2.4-6.8 Y:2.4-6.8	13	2700	1020x870x1390	131/177
JK-1903G	Special for button stitch machine	DPX17 14#	1	2	Φ8-Φ30	X:2.4-6.8 Y:2.4-6.8	10	2700	805x405x525	55/64

Note: standard function with auto presser foot lifter, auto trimming, auto thread wiping, K means it can quickly switch bartack and button stitch functions

JK-T1903GR | Electronic Button Attaching Machine

Automatic Button Feeding High Efficiency



Suitable for clothing items such as

shirts, suits, pants, down jackets, etc.



Automatic button feeding

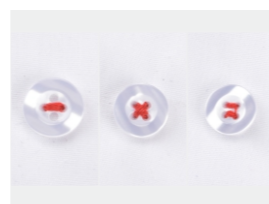

Wide range of application



Easy operation easy using



Pressure foot protection, safe and reliable

Model	application	Needle	Needle No.	Thread No.	Button diameter (mm)	Button size (mm)	Presser Foot Lifting Height (mm)	Max. Speed (s.p.m)	Volume (mm)	Weight (kg)
JK-T1903GSK	Basic Model	DP×17 14#	1	2	Φ8-Φ30	X:2.4-6.8 Y:2.4-6.8	10	2700	805×405×525	55/64
JK-T1903GR	Auto Button Feeding Device	DP×17 14#	1	2	Φ9-Φ22	X:2.4-6.8 Y:2.4-6.8	13	2700	1020×870×1390	131/177
JK-T1903GS	Button Attaching Machine	DP×17 14#	1	2	Φ8-Φ30	X:2.4-6.8 Y:2.4-6.8	10	2700	805×405×525	55/64

Note: Auto presser foot lifter, auto trimmer, auto wipper are standards. K:Bartacking and Button attaching can be transferred easily.

JK-T373G | Integrated Computerized Button Attaching Machine

Automatic Sewing, High Efficiency



Suitable for clothing items such as

shirts, suits, pants, down jackets, etc.



Shearing motor handwheel
Stepping motor, operate lightly



Stepping motor



Easy to learn and use, better performance

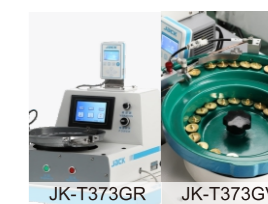

JK-T373GR JK-T373GVR
A variety of automatic button feeding devices are available

Model	Needle	Stitch No.	Thread No.	Button Diameter (mm)	Button Hole Size (mm)	Automatic Thread Trimming	Automatic Presser Foot Lifter	Presser Foot Lifting Height (mm)	Max. Speed (s.p.m)	Volume (mm)	Weight (kg)
JK-T373G	TQ×1 16#	1	1	10-28	X(2.5~6.5mm) Y(0.2.5~6.5mm)	✓	✓	10	1500	630×470×440	26/32
JK-T373GR	TQ×1 16#	1	1	8-25	X(2.5~6.5mm) Y(0.2.5~6.5mm)	✓	✓	13	1500	1220×840×1320	110/159
JK-T373GVR	TQ×7 16#	1	1	10-22	X(2.5~6.5mm)	✓	✓	13	1500	1220×840×1320	150/200

JK-T1377E | Integrated Computerized Button Attaching Machine

Automatic, Easy Shift Efficiency



Suitable for clothing items such as

shirts, suits, pants, down jackets, etc.

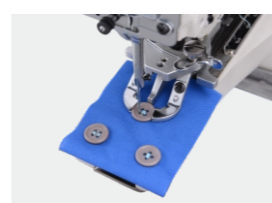

Three Patterns



Integrated, Power Saving And Environmental Protection



Lcd Operation Panel, Easy To Use

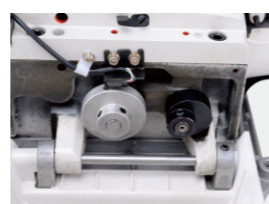

Eccentric Wheel Optimization, Operation More Stable

Model	Needle	Stitch No.	Thread No.	Button Diameter (mm)	Button Hole Size (mm)	Automatic Thread Trimming	Automatic Presser Foot Lifter	Direct Drive, Integrated	Presser Foot Lifting Height (mm)	Max. Speed (s.p.m)	Volume (mm)	Weight (kg)
JK-T1377E	TQ×1 16#	1	1	10-28	X(2.5~6.5) Y(0.2.5~4.5)	✓	✓	✓	9	1500	625×465×440	28.6/34.5

JK-2002G | Large Hook Computerized Heavy-duty Lockstitch Machine

Top And Bottom Feeding, Large Needle Gauge, Fast Speed



Suitable for clothing items such as

Shirts, jeans, non-woven bags, magic tape, shoes, bags, etc.



Top And Bottom Feeding, High Efficiency



Full Function Panel, Easy to Operate



Super Large Needle Gauge, Suitable for Light and Heavy Duty



Intelligent Double Switch

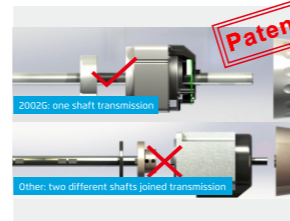

One Main Shaft

Model	Application	Needle	Thread number	Max needle gauge	Press footer height	Max speed (S.p.m)	Auto trimmer	Auto back stitch	Auto tension	Auto foot lifter	Volume (mm)	Weight (kg)
JK-2002GHC-3Z		DPx17 22#	2	8	7-16	3000	✓	✓	✓		725x285x580	37/45
JK-2002GHC-4Z	woolen	DPx17 22#	2	8	7-16	3000	✓	✓	✓	✓	725x345x580	43/51
JK-2002GHC-3Z-12	sweaters disposable	DPx17 22#	2	12	7-16	2800	✓	✓	✓		725x285x580	37/45
JK-2002GHC-4Z-12	slippers non-woven bags	DPx17 22#	2	12	7-16	2800	✓	✓	✓	✓	725x345x580	43/51
JK-2002BC-Z	hats	DPx17 22#	2	8	7-16	3000					725x285x580	37/43
JK-2002BC-Z-12		DPx17 22#	2	12	7-16	2800					725x285x580	37/43

Note: G means computerized B means Direct drive.

JK-2060G | Compound Feeding Computerized Lockstitch Machine For Heavy-duty

Full-automatic, Compound Feeding, Large Space



Suitable for clothing items such as

shirts, suits, pants, down jackets, etc.



Compound feeding



For 8 layers of leather



Large space

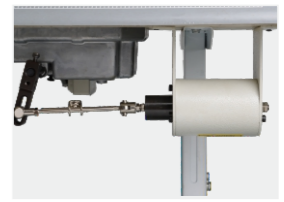

Auto presser foot lifter (optional)

Model	Application	Needle No.	Stitch No.	Thread No.	Needle Gauge (mm)	Two Presser Foot Working Distance (mm)	Presser Foot Lifting Height (mm)	Max. Speed (mm)	Automatic Thread Trimming	Auto Reverse	Electronic Thread Tension	Direct Drive, Integrated	Auto Presser Foot Lifter	Volume (mm)	Weight (kg)
JK-2060GHC-3Q	Sofa, Car Seat, Luggage, Shoes	DPx17 20-23#	1	2	1-9	2.5-5.5	8/16	2200	✓	✓	✓	✓		785x320x605	43/53
JK-2060GHC-4Q	Sofa, Car Seat, Luggage, Shoes	DPx17 20-23#	1	2	1-9	2.5-5.5	8/16	2200	✓	✓	✓	✓	✓	785x320x605	43/53

JK-2030G | Top & Bottom Feeding Computerized Lockstitch Machine For Heavy-duty

Full-automatic, Top And Bottom Feeding, Large Space



Suitable for clothing items such as

shirts, suits, pants, down jackets, etc.



Compound feeding



For 8 layers of leather



Large space

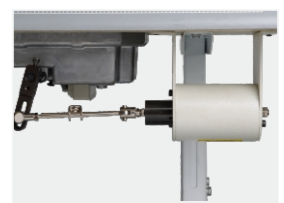

Auto presser foot lifter (optional)

Model	Application	Needle No.	Stitch No.	Thread No.	Needle Gauge (mm)	Two Presser Foot Working Distance (mm)	Presser Foot Lifting Height (mm)	Max. Speed (mm)	Automatic Thread Trimming	Auto Reverse	Electronic Thread Tension	Direct Drive, Integrated	Auto Presser Foot Lifter	Volume (mm)	Weight (kg)
JK-2030GHC-3Q	Sofa, Car Seat, Luggage, Shoes	DPx17 20-23#	1	2	1-9	2.5-5.5	8/16	2200	✓	✓	✓	✓		785x320x605	43/53
JK-2030GHC-4Q	Sofa, Car Seat, Luggage, Shoes	DPx17 20-23#	1	2	1-9	2.5-5.5	8/16	2200	✓	✓	✓	✓	✓	785x320x605	43/53
JK-2030GHC-4PQ	Sofa, Car Seat, Luggage, Shoes	DPx17 20-23#	1	2	1-9	2.5-5.5	8/16	2200	✓	✓	✓	✓	✓	785x320x605	43/53

Note: P means pneumatic presser foot lifter.

H6 Top & Bottom Feeding Computerized Lockstitch Machine For Heavy Duty(stepping Type)

Accurate Needle Stitch, Strong Feeding



Suitable for clothing items such as

Shirts, jeans, non-woven bags, magic tape, shoes, bags, etc.



Accurate needle stitch, stable and reliable

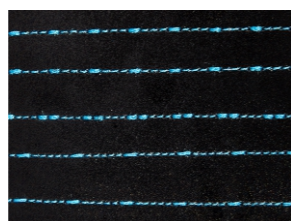

Variable stitches, fashionable and beautiful

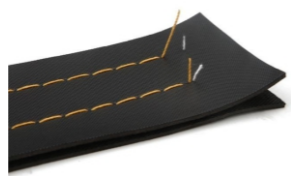

Condense stitch lock, short thread remaining

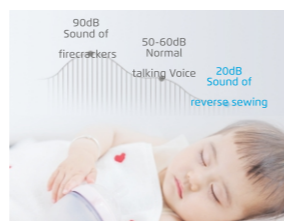

Noiseless reverse sewing, quiet and comfortable

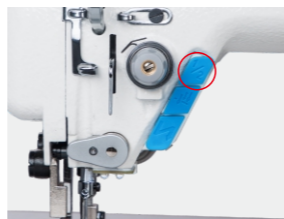

One key to switch

Model	Application	Needle	Thread no.	Needle Length (mm)	Presser Foot Lifter Height (mm)	Max Speed (s.p.m)	Auto Presser Foot Lifter	Volume (mm)	Weight (kg)
H6-CZ-3	Normal material	DPX17 20-23#	2	10	7.5-16	2200	/	725x280x558	41/48.5
H6-CZA-3	Light material	DPX17 18#	2	10	7.5-16	2200	/	725x280x558	41/48.5
H6-CZST-3	Glove	DPX17 14#	2	10	7.5-16	2200	/	725x280x558	41/48.5
H6-CZXB-3	Bag	DPX17 20-23#	2	10	7.5-16	2200	/	725x280x558	41/48.5
H6-CZZD-3	Cushion	DPX17 20-23#	2	10	7.5-16	2200	/	725x280x558	41/48.5
H6-CZ-4	Normal material	DPX17 20-23#	2	10	7.5-16	2200	electric	725x345x580	43/51
H6-CZA-4	Light material	DPX17 18#	2	10	7.5-16	2200	electric	725x345x580	43/51
H6-CZP-4	Normal material	DPX17 20-23#	2	10	7.5-16	2200	pneumatic	725x345x580	43/51
H6-CZ-3	Normal material, IoT	DPX17 20-23#	2	10	7.5-16	2200	/	725x280x558	41/48.5
H6-CZ-4	Normal material, IoT	DPX17 20-23#	2	10	7.5-16	2200	electric	725x345x580	43/51

H5 Top & Bottom Feeding Computerized Lockstitch Machine For Heavy-duty

Strong Feeding, Easy To Use



Suitable for clothing items such as

Shirts, jeans, non-woven bags, magic tape, shoes, bags, etc.



Strong Feeding, High Efficiency

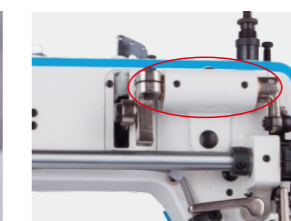

Sealed Shaft, No Oil No Trouble

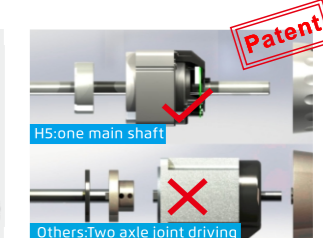

One Main Shaft



One Key To Factory Reset

Model	Application	Needle	Thread No.	Needle Gauge (mm)	Presser Foot Lifting Height (mm)	Max. Speed (s.p.m)	Automatic Presser Foot Lifting	Volume (mm)	Weight (kg)
H5-CZ-3	Normal Material	Dpx17 20-23#	2	8	7.5-16	2200		725x285x580	40.5/43
H5-CZST-3	Glove	Dpx5 11-17#	2	8	5-16	1800		725x285x580	40.5/43
H5-CZXB-3	Bag	Dpx17 20-23#	2	8	7.5-16	2200		725x285x580	40.5/43
H5-CZZD-3	Cushion	Dpx17 20-23#	2	8	7.5-16	2200		725x285x580	40.5/43
H5-CZ-4	Normal Material	Dpx17 20-23#	2	8	7.5-16	2200	✓	725x345x580	43/45.5
H2-CZ	Normal Material	Dpx17 20-23#	2	8	7.5-16	2200		725x285x580	40.5/43
H2-CZ-12	Normal Material	Dpx17 20-23#	2	12	7.5-16	2200		725x285x580	40.5/43
H2-CZST	Glove	Dpx5 11-17#	2	8	5-16	1800		725x285x580	40.5/43
H2-CZXB	Bag	Dpx17 20-23#	2	8	7.5-16	2200		725x285x580	40.5/43
H2-CZZD	Cushion	Dpx17 20-23#	2	8	7.5-16	2200		725x285x580	40.5/43

H5K Side Cutter Synchronous Computerized Heavy Duty Lockstitch Sewing Machine

Neat Cutting Edge, Separated Cutter, And Strong Durability



Separated cutter, good durability

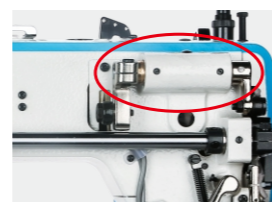

Sealed design, no oil and no worries



Integration of mechanical and electric, Easy to use



Free setting, one key reset

Suitable for clothing items such as

shirts, suits, pants, down jackets, etc.

Model	Needle	Thread no.	Needle Length (mm)	Presser Foot Lifter Height (mm)	Max Speed (s.p.m)	Auto Presser Foot Lifter	Volume (mm)	Weight (kg)
H2K-CZ	DPX17 20-23#	2	8	7-16	2000	/	725×280×558	39/46
H5K-CZ-3	DPX17 20-23#	2	8	7-16	2000	/	725×280×558	39/46
H5K-CZ-4	DPX17 20-23#	2	8	7-16	2000	Electric	725×345×580	43.5/45.5
H5K-CZP-4	DPX17 20-23#	2	8	7-16	2000	pneumatic	725×345×580	43.5/45.5

Note: The standard cutting width is 4.8mm, optional 3.2mm, 6.4mm

H2 Top & Bottom Feeding Direct Drive Lockstitch Machine For Heavy Duty

Top And Bottom Feeding, Strong Feeding, Big Stitch Length



Sealed presser foot lifter shaft, no oil, no trouble

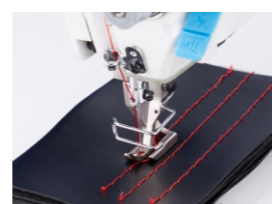

Strong feeding, power saving and high efficiency



Smart panel, easy to use



Cooling fan

Suitable for clothing items such as

shirts, suits, pants, down jackets, etc.

Model	Application	Needle	Thread No.	Stitch Length (mm)	Presser Foot Lifting Height (mm)	Max. Speed (S.p.m)	Volume (mm)	Weight (kg)
H2-CZ	Normal Materials	DPx17 20-23#	2	8	7.5-16	2000	725×285×580	40.5/43
H2-CZ-12	Sofa, Car Seat, Curtain Etc	DPx17 20-23#	2	12	7.5-16	2000	725×285×580	40.5/43
H2-CZST	Gloves, Handbag Etc	DPx17 20-23#	2	8	7.5-16	2000	725×285×580	40.5/43
H2-CZXB	Luggage	DPx17 20-23#	2	8	7.5-16	2000	725×285×580	40.5/43
H2-CZZD	Car Seat	DPx17 20-23#	2	8	7.5-16	2000	725×285×580	40.5/43

S7 Intelligent-Control Computerized Post Bed Roller Feed Sewing Machine

Accurate Needle Stitch, Noiseless And Faster



Suitable for clothing items such as

Shirts, jeans, non-woven bags, magic tape, shoes, bags, etc.

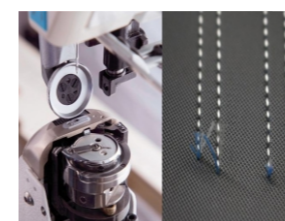

Short Thread Remaining (optional)



Rotary Type Pressure Adjustment, Easy To Adjust



Different Stitch Length, Free Switching

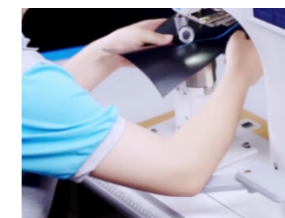

New Reverse Wrench, Operate Easily

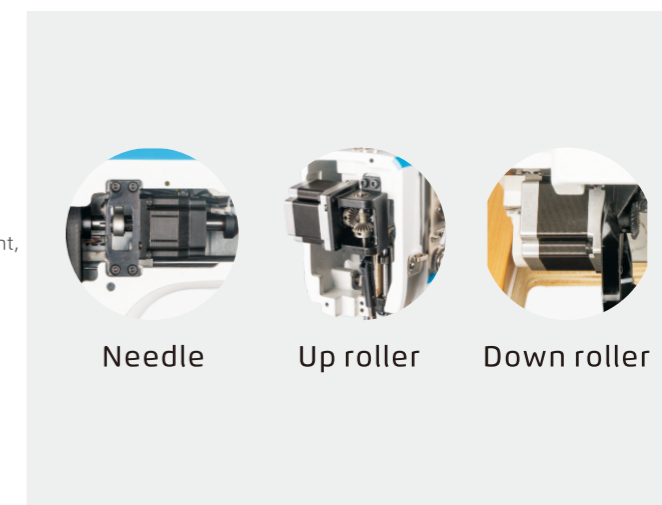

Stepper Motor Drive, Accurate Stitch

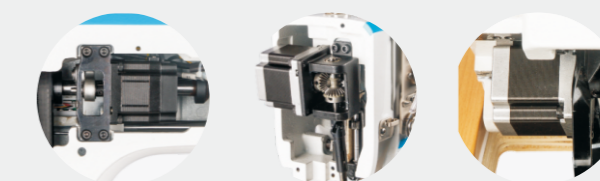

Needle

Up roller

Down roller

Model	Max.Speed (S.p.m)	Needle	Presser Foot Lifter Height (mm)	Maximum Stitch Length (mm)	Needle Bar Stroke	Auto Trimmer	Auto Reverse Sewing	Auto Presser Foot Lifter	Short Thread Tail	Volume (mm)	Weight (kg)
S7-91-T	2500	DP×5 9-23#	12	5	41	✓	✓	✓		882×375×794	63/72
S7-92-T	2000	DP×5 9-23#	12	5	41	✓	✓	✓		882×375×794	63/72
S7-91	2500	DP×5 9-23#	12	5	41	✓	✓	✓		882×375×794	63/72
S7-92	2000	DP×5 9-23#	12	5	41	✓	✓	✓		882×375×794	63/72
S7-91CX-T	2500	DP×5 9-23#	12	5	41	✓	✓	✓	✓	882×375×794	63/72
S7-91CX	2500	DP×5 9-23#	12	5	41	✓	✓	✓	✓	882×375×794	63/72

Note: Button is standard, T:LCD, X:Short thread tail, C:Chinese hook

S5 High Speed Computerized Post Bed Roller Feed Sewing Machine

Beautiful Stitches, Quick Service, Easy to Use



Suitable for clothing items such as

shirts, suits, pants, down jackets, etc.

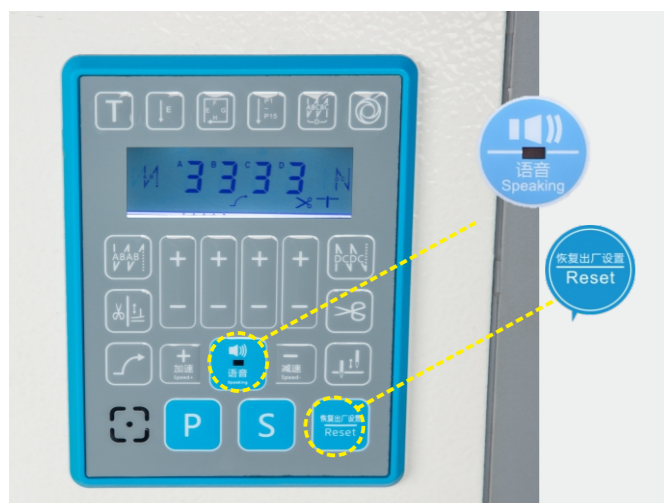

Built-in Panel, Easy to Operate

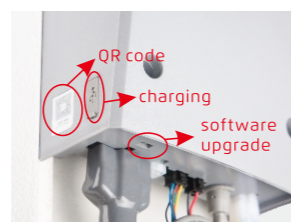

Intelligent control double USB

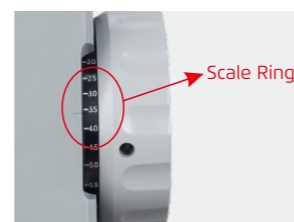

Aluminum Handwheel with Scale Ring



Stitch Overlapping Ratio 100%

Model	Max. Speed (S.p.m)	Needle	Presser Foot Lifter Height (mm)	Max. Stitch Length (mm)	Needle Bar Stroke (mm)	Automatic Thread Trimmer	Auto Backstitch	Auto Presser Foot Lifter	Short Tail	Volume (mm)	Weight (kg)
S5-91	3000	INDPX5#16	12	6.3	41	✓	✓	✓		812×375×724	67/76
S5-91CX	3000	INDPX5#16	12	6.3	41	✓	✓	✓	✓	812×375×724	67/76
S5-92	2000	INDPX5#16	12	4.1	41	✓	✓	✓		812×375×724	67/76

JK-6591C/6592C Direct Drive Post Bed Sewing Machine

Power Saving And High Efficiency



Suitable for clothing items such as

shirts, suits, pants, down jackets, etc.

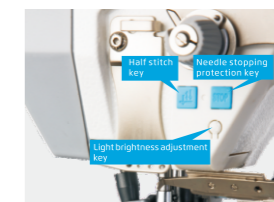

Humanized design, convenient and practical



Up and down needle position, simple and convenient



Power saving and high efficiency



Easy to operate, to be professional

Model	Max. Speed (s.p.m)	Needle	Presser Foot Lifting Height (mm)	Max Stitch Length (mm)	Needle Bar Stroke (mm)	Volume (mm)	Weight (kg)
JK-6591C	3000	INDPX5#16	12	6.3	41	61/67	812x375x724
JK-6592C	2000	INDPX5#16	12	4.1	41	61/67	812x375x724

JK-6671C/6672C Intelligent-Control Computerized Post Bed Roller Feed Sewing Machine

Integration Of Mechanical And Electric, Cost-effective



Suitable for clothing items such as

shirts, suits, pants, down jackets, etc.



Voice Guide, One-key Factory Reset

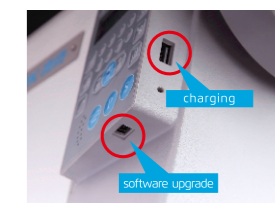

Intelligent control double USB



Integrated Control Box , High Efficiency

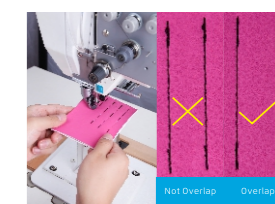

Repeated Stitch Rate Is 100%

Model	Max.Speed (S.p.m)	Needle	Presser Foot Lifter Height (mm)	Max.Stitch Length (mm)	Needle Bar Stroke (mm)	Automatic Thread Trimmer	Auto Backstitch	Auto Presser Foot Lifter	Volume (mm)	Weight (kg)
JK-6671C	3000	INDPX5#16	12	6.5	41	✓	✓	✓	812×375×724	71
JK-6672C	3000	INDPX5#16	12	5	41	✓	✓	✓	812×375×724	71

JK-H1680 Automatic Three-stage Double-head Intelligent Line Drawing Machine

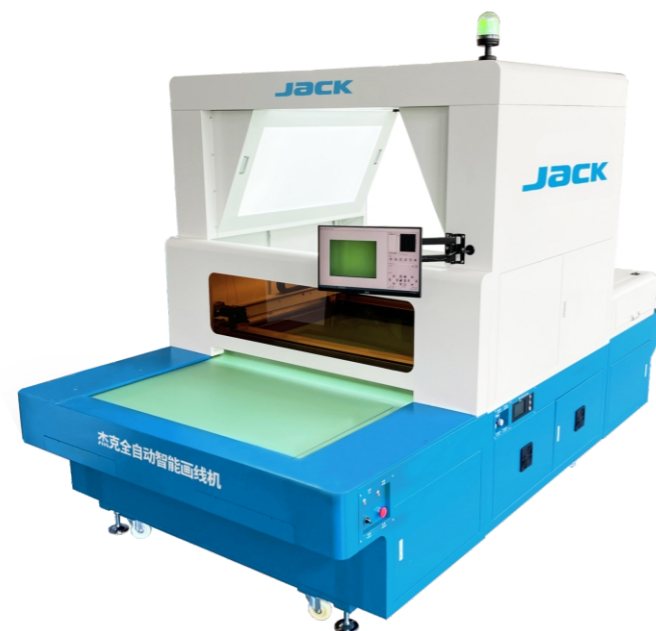

JK-H1680 Intelligent line drawing machine VS Traditional manual line drawing

Line drawing contrast	Single head automatic line drawing	Double-head automatic line drawing	Line drawing by hand	Remark
Line drawing efficiency	1 hour 2500 pieces	1 hour 4000 pieces	1 hour 400 pieces	Capacity ≥10 times
Line drawing accuracy	≥99%	≥99%	≤90%	Higher precision of machine drawing
Labor cost	One person	One person	Six-ten persons	One machine can replace six-ten persons
Sample making cost	No need to make a plate for different style parts size	No need to make a plate for different style parts size	Each type needs to be plated	Machine saves high cost

Function introduction

JK-H1680 is a automatic three-stage double-head intelligent line drawing machine, the body can be split into three sections, which is convenient for transportation; the number of line-drawing nozzles is upgraded from single-head to double-head, which realizes the improvement of the machine's line-drawing speed And software function upgrades. Maximize work efficiency, minimize production costs, and help enterprises upgrade and transform.

Application field



Footwear industry: line drawing on shoe materials

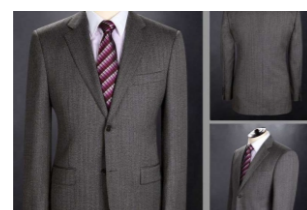

Clothing industry: line drawing on apparel fabrics



Luggage industry: leather, PU, fabric

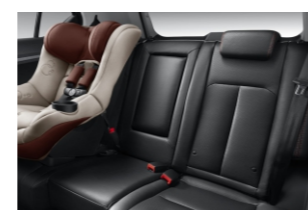

Automobile interior industry: leather, PU and other composite materials

Model	Nozzles quantity	Working area (mm)	Line drawing speed (mm/s)	Line drawing accuracy (mm)	Rated power (kw)	Frequency (hz)	Air pressure requirement (map)	Maximum size (mm)	Weight (kg)
JK-H1680	double-end	1600×800	2500	±0.1	3.3	50-60	0.4-0.8	3500x2020x2300	1029
JK-H1280	single-end	1200×800	2500	±0.1	2.2	50-60	0.4-0.8	3200x2020x2300	960

Programmable Electronic Pattern Sewing Machine Series

Full-automatic, Programmable, High Efficiency



Suitable for clothing items such as

Shirts, jeans, non-woven bags, magic tape, shoes, bags, etc.

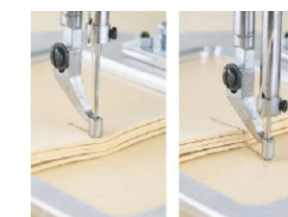

Intelligent central presser foot



For heavy duty



Visual operation

Wide range of application

Model	Optional Device	Needle	Stitch No.	Thread No.	Sewing Rang (mm)	Presser Foot Lifting Height (mm)	Max. Speed (s.p.m)	Volume (mm)	Weight (kg)
JK-T1310	F1	DPx17 11-25#	1	2	130×100	22	2700	1220×840×1320	140/184 140/189(Reinforce)
JK-T2210	F1,F3,K	DPx17 11-25#	1	2	200×100	22	2700	1220×840×1320	142/186 142/191(Reinforce)
JK-T3020	F4,K,TDB	DPx17 11-25#	1	2	300×200	22	2700	1220×1220×1320	216/280 216/293(Reinforce)
JK-T6040	-	DPx17 11-25#	1	2	600×400	22	2500	1920×1620×1420	347/480 347/508(Reinforce)
JK-T10040	-	DPx17 11-25#	1	2	1000×400	22	2500	1920×1620×1420	367/500 367/528(Reinforce)

Note: 1. F1: flip presser foot, F3-2210sideslip presser foot, F4-3020sideslip presser foot, K: clamping device, TDB: pocket attaching.
2. factory standard machine needle DPX17 19#.
3. F1 F2 F3 F4 TDB equipment sewing range subject to actual.

CONFIGURATION

Shirt

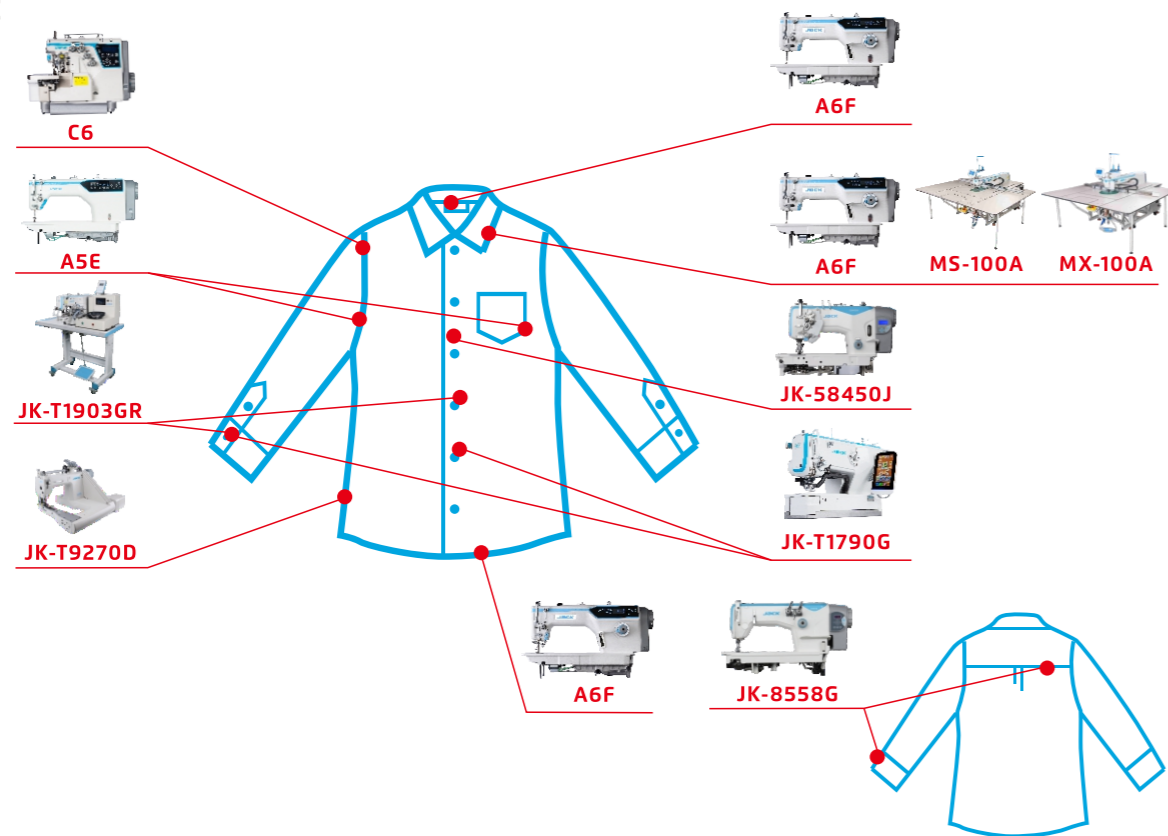

Jeans

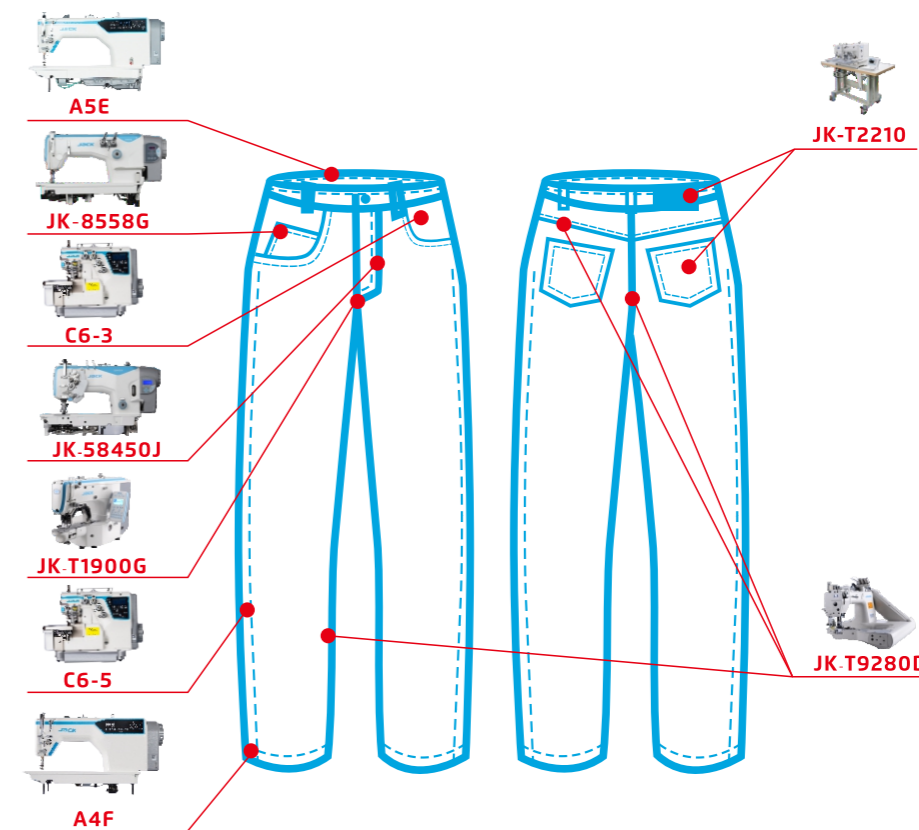

Trousers

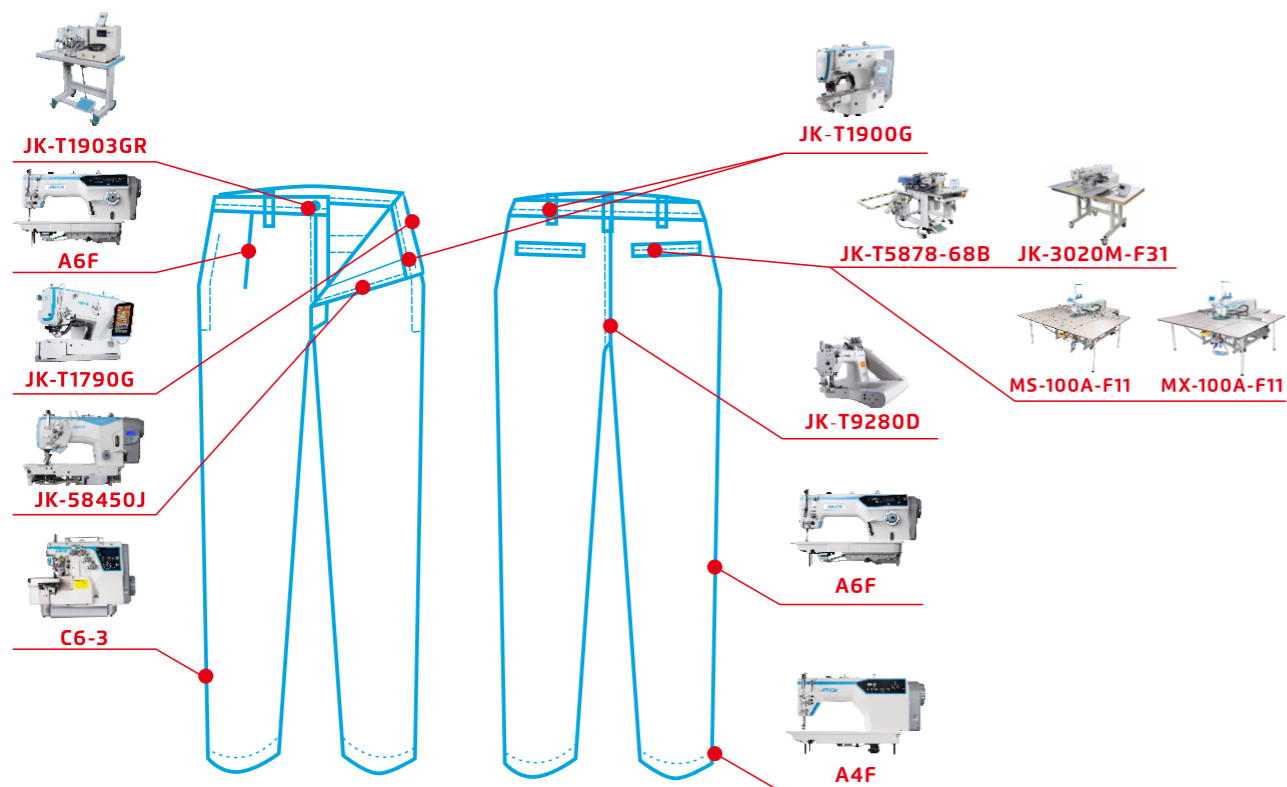

Bra

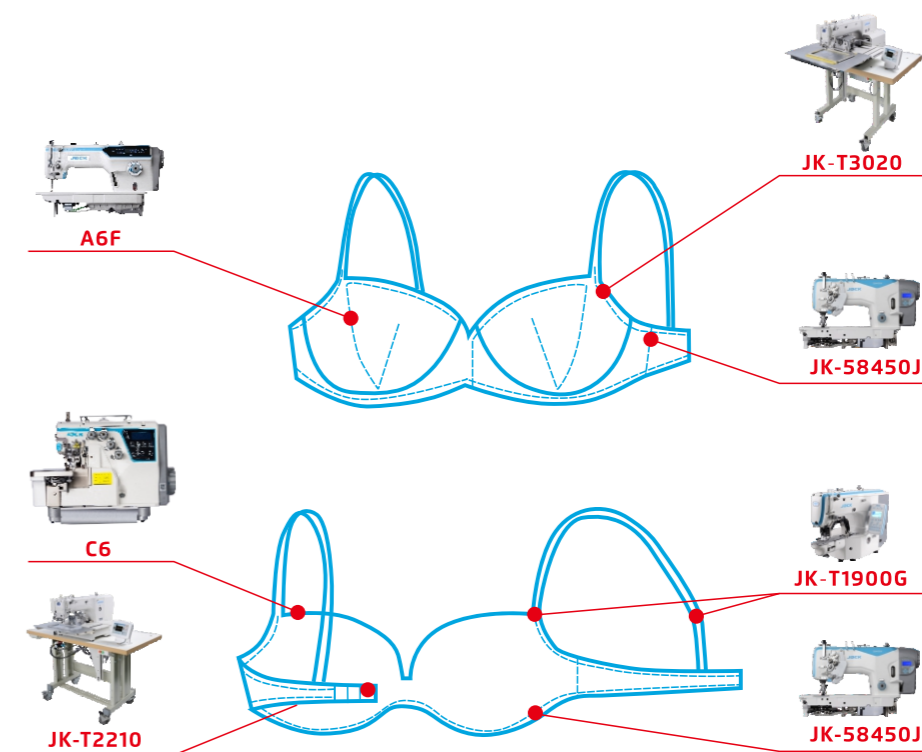

Briefs

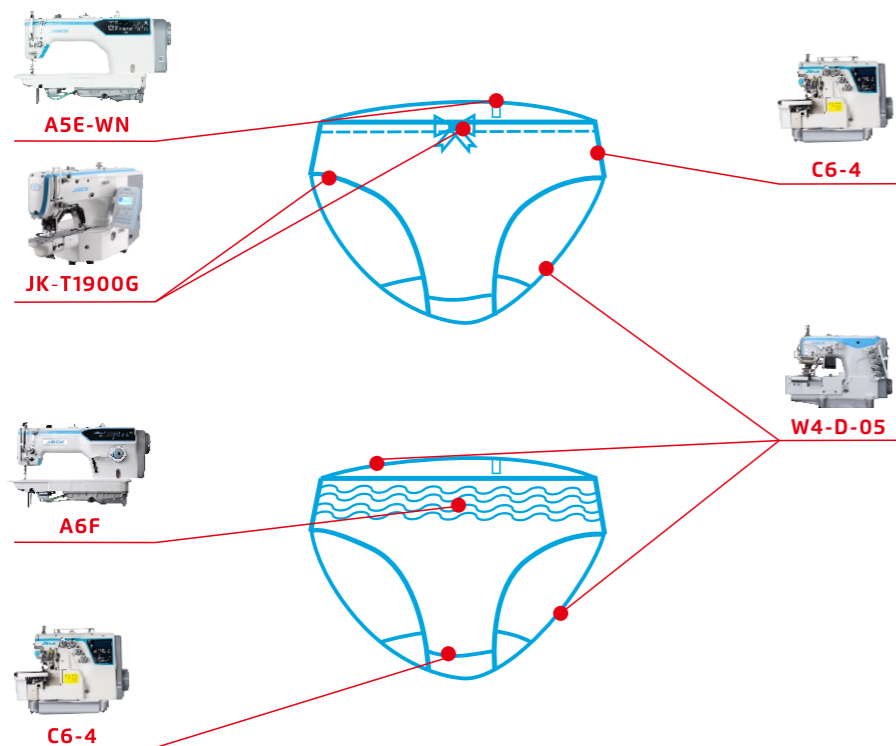

Dresses

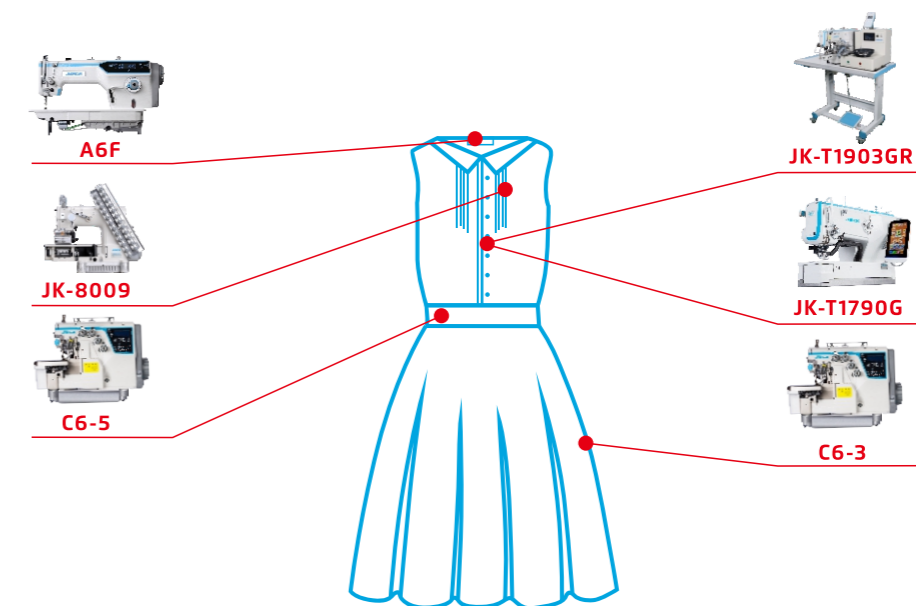

Polo-shirt

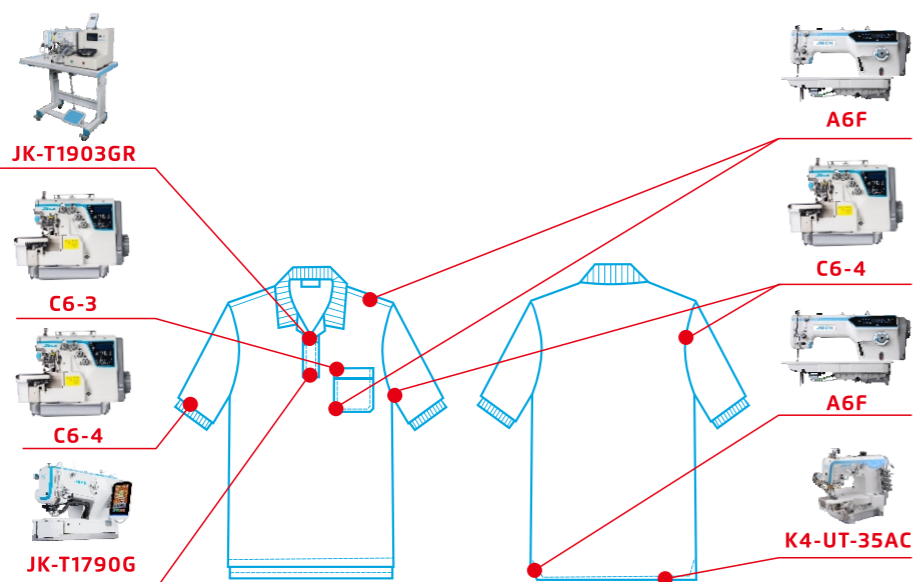

Bag

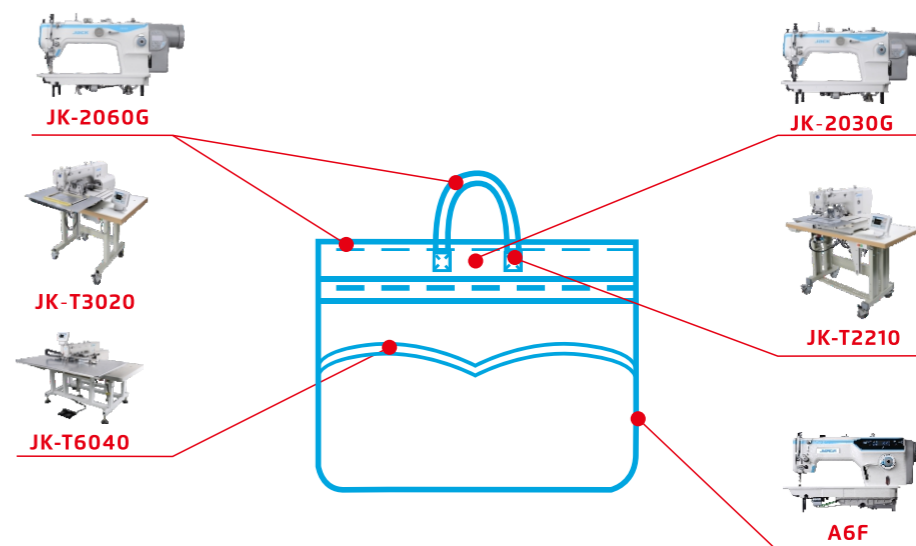

STITCH TABLE

Lockstitch



Lockstitch with short thread tail



Edge cut and tape binder



Cutting after sewing



Double needle lock stitch

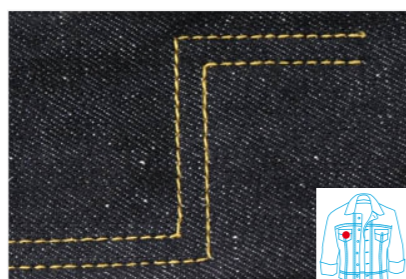

Double needle corner stitch

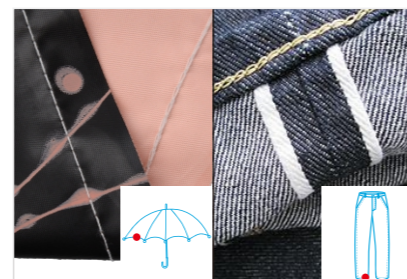

Single needle chain stitch

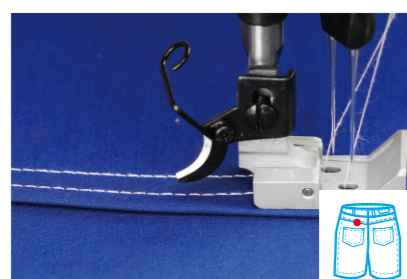

Double needle chain stitch

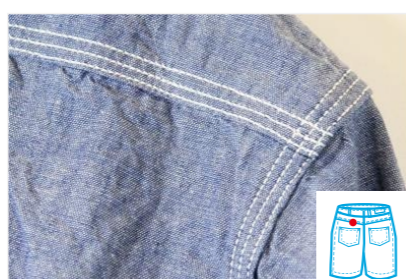

Triple needle chain stitch

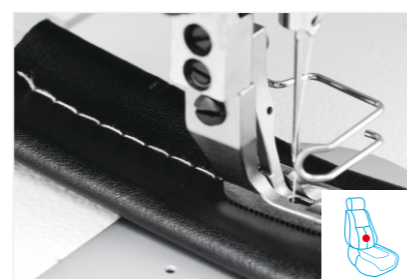

Heavy duty

Overlock



Pocket double chain stitch



Fabric joint sewing

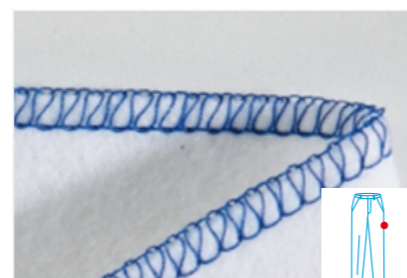

Three threads stitch

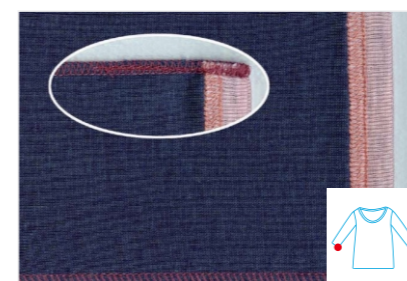

Three threads back latching stitch

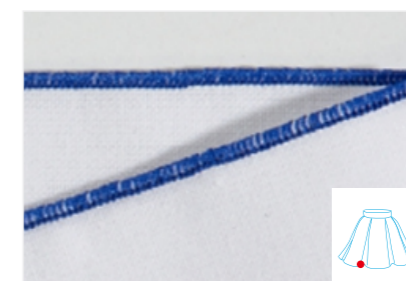

Three threads baby overlock stitch



Three threads blindstitch hemming

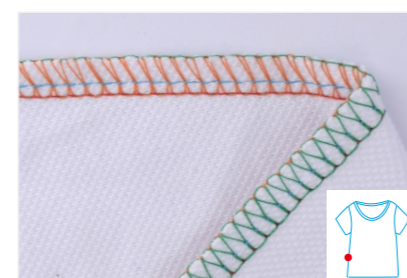

Four threads stitch



Four threads back latching stitch



Four threads shirring stitch



Four thread tape attach stitch



Five threads stitch



Five threads heavy duty stitch

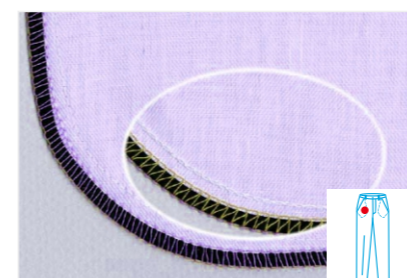

Five threads for attaching tape



Six threads sewing



Four threads variable top feed

Four Thread Interlock

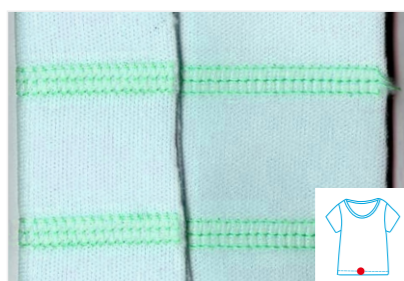

Plain seaming

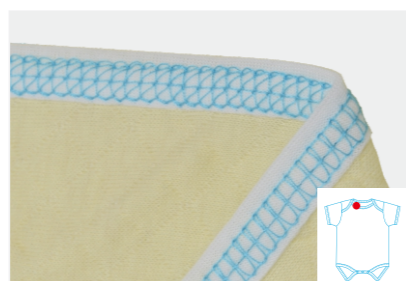

Tape binding



Covering stitch (one side)



Covering stitch

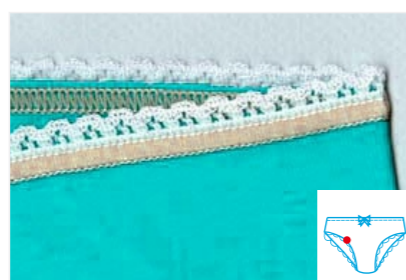

Elastic lace attaching

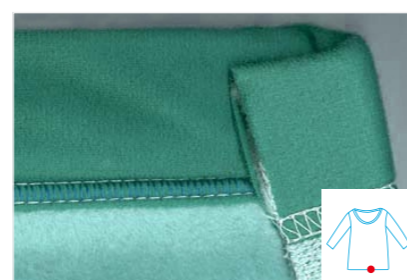

Bottom hemming

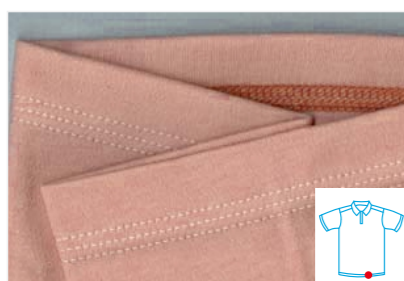

Bottom hemming (left cutter)



Cylinder cover stitch



Elastic attaching

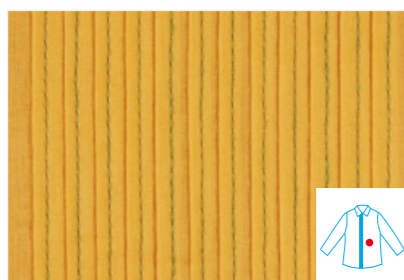

T-shirt folding seaming



Tape attaching



Waist band

Button Holing/Button Attaching

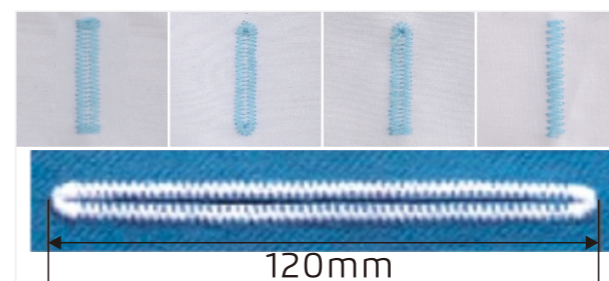

Button holing stitch

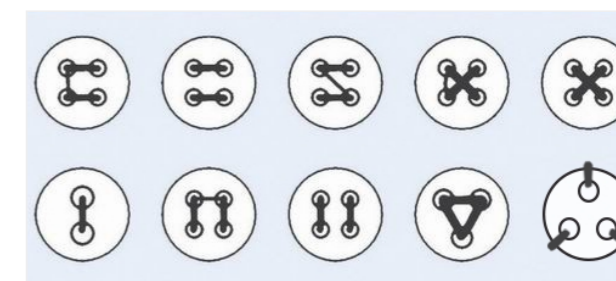

Button attaching stitch

Bartacking Machine Stitch



Bartacking stitch



Cap hole stitch

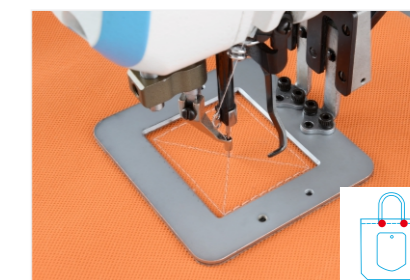

Small pattern

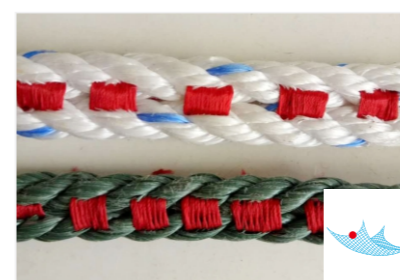

Fishing net

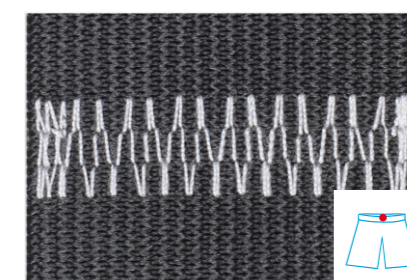

Elastic joint

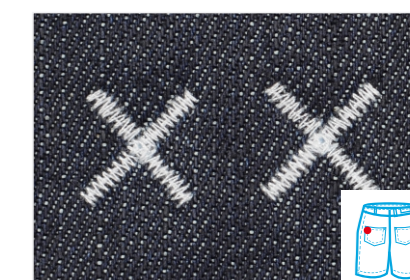

Cross bartacking stitch

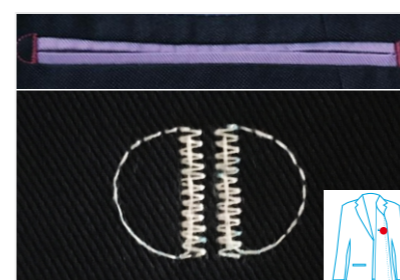

Suits bartacking stitch

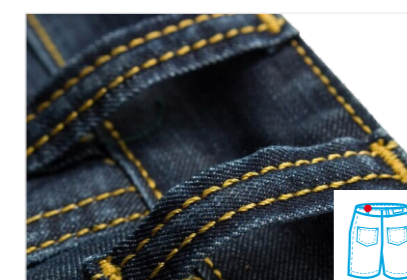

Jeans bartacking stitch

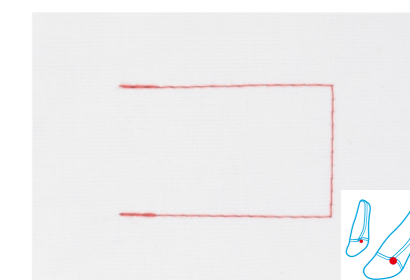

Bartacking for socks

Pattern Stitch

Apparel



Non-apparel

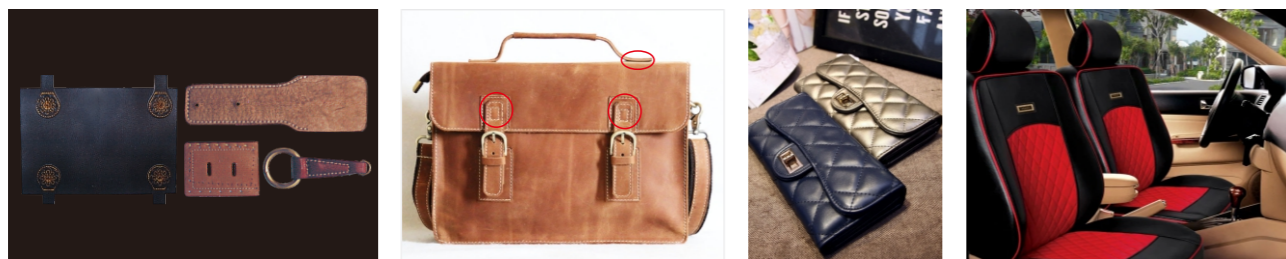

Home textile



Others



Chain Stitch



Triple needle feed-off-the arm machine



Double needle feed-off-the arm machine

Placket Samples



Visible placket

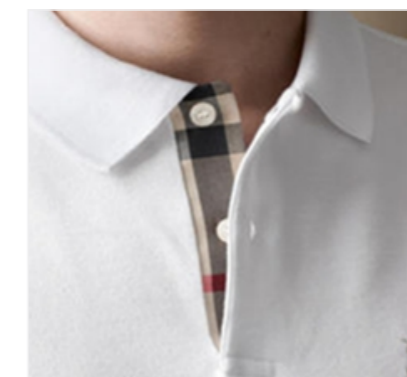

Invisible placket



"V" placket

Pocket Stitch



Single welt pocket



Double welt pocket



Double welt pocket with flap